



CATALOGUE 2026

COSTER

HISTORY	13
WHAT WE DO	15
TOTAL CONTROL OF THE BUILDING	17
WEB GARAGE	20
LICENCES AND MAINTENANCE	29
PROGRAMMABLE CONTROLLERS	33
ROOM CONTROL	41
LIGHT CONTROL	45
CONFIGURABLE CONTROLLER GPC 642	51
SYSTEM ARCHITECTURE	55
MONITORING	67
X SERIES	89
ROOM CONTROL	109
DOMESTIC WATER MIXING	113
GAS SAFETY	119
VALVES AND ACTUATORS	131
SENSORS, ACCESSORIES, REMOTE CONTROLS	163
CONNECTIVITY AND ACCESSORIES	175

Alphanumeric index

2...3

Code	page
2F DN 50	142
2F DN 65	142
2F DN 80	142
2F DN 100	142
2F DN 125	142
2F DN 150	142
2F DN 200	142
2FT40	142
2FT50	142
2FT65	142
2FT80	142
2FT100	142
2FT125	142
2FT150	142
2FT200	142
2S DN 40	140
2S DN 50	140
2S DN 65	140
2S DN 80	140
2S DN 100	140
2S DN 100S	140
2S DN 125	140
2S DN 150	140
2S DN 200	140
3 IMP	73-78

A

Code	page
ACB 232	183
ACB 232 / S1	183
ACB 332	179
ACB 400	182
ACB 460	182
ACB 468	182
ACC 019	122
ACC 060	122
ACC 150	122
ACC 240	122
ACC 400	122
ACD 455	120
ACD 655	91-108
ACE 004/P	146
ACE 008/P	146
ACM 103	166,170
ACS 232	183

ACX 232	182
AGT 10	135
AGT 12	135
AGT 14	135
AGT 15	135
AGT 16	135
AH-20	161
AH-25	161
AH-GMA	161
AH-TF	161
ALD 018	128
ALD 110	112
ALI 310	122
ALM 1210	39
ALM 1225	39
ALM 2436	177
ALM M12	146
ALP 114	122
ALP 120	122
ANT 500D	177
ANT 868	38, 165
APA 500	38, 69, 70
APV 100	167
ARE 338	177
ARS 604B	154
ASA 010	98
ASA 420	91, 92, 98
ATC 220	112
ATC 24	132
ATC 220S	132
ATC 24S	132
ATC M24	132
ATR 868	134
AUX M12	146
AVA 101	143 - 144
AVC 20-100	146
AVF 171	145
AVF 172	145
AVX 10-32	146
AVX 40-50	146
AVY 15-32	146
AVY 40-50	146
AVS 103	143, 144

AVS 104	143, 144
---------	----------

B

Code	page
BDL 001	45
BDL 002	45
BDL 004	45
BME ...	84-85
BRG 868	69
BRG 868C	69
BRK 001	72
BRK 003	72

C

Code	page
CAP 328	102
CDB 100	174
CDB 200	174
CDB 300	174
CDB 300/S1	174
CDB 301	174
CDB 333	174
CDK 032	134
CDK 034	134
CDK 038	134
CDK 062	134
CDK 064	134
CDK 068	134
CFL 104	162
CFL 124	162
CFL 124/C	162
CFL 128	162
CFL 128/C	162
CFL 134	162
CFS 404	162
CFS 404/C	162
CFS 424	162
CFS 424/C	162
CFS 428	162
CFS 428/C	162
CFT 004	162
CFT 024	162
CFT 024/C	162
CFT 028	162
CFT 028/C	162
CLAV 214	155
CLAV 218	155

CLAV 254-0	155
CLNF U254	156
CLNF U254-0	156
CLNF U254R-0	156
CLNF U258R	156
CLNV 214	156
CLNV 218	156
CLNV 254-0	156
CLNV 314	156
CLNV 314-R	156
CLNV 318	156
CLNV 318-R	156
CLNV 354-0	156
CLNV 354R-0	156
CMC 328	71
CMC 422	71
CMC 428	71
COP 868	164
COSTERTOOLS	176
CRB 094	143
CRB 098	143
CRB 098/S2	143
CSA 344	100
CSC 328	101
CSG 804	160
CSG 834	160
CSG 834/C	160
CSG 838	160
CSG 838/C	160
CSL 104	160
CSL 134	160
CSL 134/C	160
CSL 138	160
CSL 138/C	160
CSL 882	123
CSN 204	160
CSN 234	160
CSN 234/C	160
CSN 238	160
CSN 238/C	160
CSS 404	160
CSS 434	160
CSS 434/C	160
CSS 438	160
CSS 438/C	160
CSV 328	101
CSW 868	38, 165
CVC 014	143
CVC 014/T	143
CVC 018	143
CVC 018/T	143

CVC 034	143
CVC 034/T	143
CVC 038	143
CVC 038/T	143
CVC 094	143
CVC 094/T	143
CVC 098	143
CVC 098/T	143
CVC 184	143
CVC 184/T	143
CVC 188	143
CVC 188/T	143
CVF 154	145
CVF 158	145
CVF 454	145
CVF 458	145
CVH 054	144
CVH 054/T	144
CVH 058	144
CVH 058/T	144
CVH 114	144
CVH 114/T	144
CVH 118	144
CVH 118/T	144
CVH 214	144
CVH 214/T	144
CVH 218	144
CVH 218/T	144
CVH 634	144
CVH 634/T	144
CVH 638	144
CVH 638/T	144
CVLR 095	152
CVLR 095-0	152
CVLR 095-MOD	152
CVLR 097	152
CVQ 095	159
CVQ 095-0	159
CVQ 097	159
CVS 808	144
CWC 100	30
CWC 01K	30
CWS 100	30
CWS 200	30
CWS 500	30
CWS 01K	30
CWS 02K	30
CWS 05K	30

CWS 10K	30
CWS 50K	30
CWS 01K_MAINT	31
CWS 02K_MAINT	31
CWS 05K_MAINT	31
CWS 10K_MAINT	31
CWS 100_MAINT	31
CWS 200_MAINT	31
CWS 500_MAINT	31
CWS 50K_MAINT	31
CWS 100_MAINT-2	31
CWS 200_MAINT-2	31
CWS 500_MAINT-2	31
CWS 01K_MAINT-2	31
CWS 02K_MAINT-2	31
CWS 05K_MAINT-2	31
CWS 10K_MAINT-2	31
CWS 50K_MAINT-2	31
CWS 100_MAINT-4	31
CWS 200_MAINT-4	31
CWS 500_MAINT-4	31
CWS 01K_MAINT-4	31
CWS 02K_MAINT-4	31
CWS 05K_MAINT-4	31
CWS 10K_MAINT-4	31
CWS 50K_MAINT-4	31

D

Code	page
DAM 675	98
DCF 648	92
DDM 328	102
DEP 648	112
DEP 658	112
DEP 678	112
DGD 118	121
DGD 148.15	121
DGD 148.20	121
DGD 148.25	121
DGD 218	121
DGD 248.15	121
DGD 248.20	121

DGD 248.25	121
DGD 318	121
DGT 110	135
DGT 110/R	135
DGT 115	135
DGT 115/R	135
DGT 120	135
DGT 210	135
DGT 210/R	135
DGT 215	135
DGT 215/R	135
DGT 220	135
DPS 638	104
DRP 414	100
DRU 414	104
DRU 418	104
DRU 614	104
DRU 618	104
DSP 120	35
DTC 648	91
DTF 314	103
DTF 318	103
E	
Code	page
EBR 868	38
EBR 868C	38
EHC 01K	34, 68
EHC 02K	34, 68
EHC 100	34, 68
EHC 200	34, 68
EHC 500	34, 68
EHC 602	34, 68
EQL 060	83
EQL 250	83
EQX 424	83
ESP 442	37
ESU 402	37
EST 482	37, 69
ETH 338	177
F	
Code	page
FCF 223	161
FCM 15-20-25	129
FCM 32-40	129

FCM 50	129
FCM 65-80	129
FCM 100	129
FCM 125-150	129
FCR ...	126
FCS 123	161
FCS 2A	155, 156
FCS 223	152
G	
Code	page
GAR 232	127
GAR 432	127
GAR 832	127
GAR 240	127
GAR 440	127
GAR 840	127
GAR 250	127
GAR 450	127
GAR 850	127
GAR 265	127
GAR 465	127
GAR 865	128
GAR 280	128
GAR 480	128
GAR 880	128
GAR 2100	128
GAR 4100	128
GAR 8100	128
GAR 2125	128
GAR 4125	128
GAR 8125	128
GAR 2150	128
GAR 4150	128
GAR 8150	128
GAR 2200	128
GAR 4200	128
GAR 8200	128
GAR 2300	128
GAR 4300	128
GAR 8300	128
GARO 215	124
GARO 220	124
GARO 225	124
GARO 415	124
GARO 420	124
GARO 425	124
GARO 815	124
GARO 820	124
GARO 825	124
GCA 215	129
GCA 220	129
GCA 225	129
GCA 415	129
GCA 420	129

GCA 425	129
GCA 432	129
GCA 440	129
GCA 450	129
GCA 465	129
GCA 480	129
GCA 815	129
GCA 820	129
GCA 825	129
GCA 832	129
GCA 840	129
GCA 850	129
GCA 865	129
GCA 880	129
GCA 4100	129
GCA 4125	129
GCA 4150	129
GCA 4200C	129
GCA 4250C	129
GCA 4300C	129
GCA 8100	129
GCA 8125	129
GCA 8150	129
GCA 8200C	129
GCA 8250C	129
GCA 8300C	129
GCAO 210	123
GCAO 215	123
GCAO 220	123
GCAO 410	123
GCAO 415	123
GCAO 420	123
GCAO 810	123
GCAO 815	123
GCAO 820	123
GCR 815	125
GCR 415	125
GCR 215	125
GCR 820	125
GCR 420	125
GCR 220	125
GCR 825	125
GCR 425	125
GCR 225	125
GCR 832	125
GCR 432	125
GCR 232	125
GCR 840	125
GCR 440	125
GCR 240	125
GCR 850	125
GCR 450	125
GCR 250	125

GCR 865	126
GCR 465	126
GCR 265	126
GCR 880	126
GCR 480	126
GCR 280	126
GCR 8100	126
GCR 4100	126
GCR 2100	126
GCR 8125	126
GCR 4125	126
GCR 2125	126
GCR 8150	126
GCR 4150	126
GCR 2150	126
GCR 8200	126
GCR 4200	126
GCR 2200	126
GCR 8300	126
GCR 4300	126
GCR 2300	126
GCRO 215	124
GCRO 220	124
GCRO 225	124
GCRO 415	124
GCRO 420	124
GCRO 425	124
GCRO 815	124
GCRO 820	124
GCRO 825	124
GIS 062	77, 78
GIS 090	166
GIS 090/INOX	166
GIS 112	77, 78
GIS 160	166, 170
GIS 160/INOX	166, 170
GIS 500	166, 170
GIS 500/INOX	166, 170
GPC 642	52
GSP 485	70
GTW 232485	178
GVC 348	180
H	
Code	page
HGM 210	133
HGM 215	133
HGM 220	133
HGM 225	133
HMM 210	133
HMM 215	133

HMM 220	133
HMM 225	133
HMM 320	133
HMM 325	133
HMM 410	133
HMM 415	133
HMM 420	133
I	
Code	page
IEF 276-10	77
IEF 276-100	77
IEF 276-1000	77
IEM 277-10	78
IEM 277-100	78
IEM 277-1000	78
IEW 278-10	78
IEW 278-100	78
IEW 278-1000	78
IPG 318	99
IPS 328	100
ISC 648	91, 92
J	
Code	page
JOY 879W	43
JOY 771W	43
JOY 363W	43
K	
Code	page
KBHF 50-15	81
KBHF 65-25	81
KBHF 80-40	81
KBHF 100-60	81
KBHF 125-100	81
KBHF 150-150	81
KBHF 200-250	81
KBHF 250-400	81
KBHF 300-600	81
KG 10	161
KH 8	161
KH-AFB	161
KH-LF	161
KIT 668	178
KMF 15D	79
KMF 20D	79
KMF 25C	79
KMF 32C	79
KMF 40C	79
KMF 50C	79
KMHG 25-3,5	81

KMHG 25-6	81
KMHG 40-10	81
KUC 15 D	76
KUC 15W-N	77
KUC 20 D	76
KUC 20W-N	77
KUF 15 D	76
KUF 15W-N	77
KUF 20 D	76
KUF 25 C	76
KUF 20W-N	77
KWM 50/C1	80
KWM 65/C1	80
KWM 80/C1	80
KWM 100/C1	80
KWM 125/C1	80
KWM 150/C1	80
KWP 50C	80
KWP 65C	80
KWP 80C	80
KWP 100C	80
KWP 125C	80
KWP 150M	80
KWP 200M	80
L	
Code	page
LCF 363W	43
LCF 364W	43
LCF 571	43
LCF 572	43
LCF 771W	43
LCR 348	101
LGP 250	172, 181
LGP 500	172, 181
M	
Code	page
MAS 615	116
MAS 620	116
MAS 625	116
MAS 632	116
MAS 615/AL	117
MAS 620/AL	117
MAS 625/AL	117
MAS 632/AL	115
MAS 615/T	114
MAS 620/T	114
MAS 625/T	114
MAS 632/T	114
MAS 615/T/AL	115
MAS 620/T/AL	115

MAS 625/T/AL	115
MAS 632/T/AL	115
MAS 740	116
MAS 740/AL	117
MAS 740/T	114
MAS 740/T/AL	115
MAS 750	116
MAS 750/AL	117
MAS 750/T	114
MAS 750/T/AL	115
MDM 002	178
MDM 003	178
MDM 232	178
MFD 418	72
MFD 438	72
MFD 448	72
MFD 548	72
MHF 15-1,5	73
MHF 20-2,5	73
MHN 15-1,5	73
MHN 20-2,5	73
MHR 15-1,5	74
MHR 20-2,5	74
MRL 608	110
MWM 000	71
O	
Code	page
OCR 348	100
P	
Code	page
PBD 400	47
PCB 332	179
PCB 432	180
PCP 868	70
PCS 104	161
PDA 004	45
PDD 001	46
PDD 002	46
PDD 003	46
PDD 004	46
PDD 005	47

PDS 001	47
PDF 795	174
PLE 608	98
PME ...	84,85
PRU 002	42
PRU 002/B	42
Q	
Code	page
Q380	40
Q381	40
Q382	40
Q383	40
Q384	40
Q880	40
Q881	40
Q882	40
Q883	40
Q884	40
QGP0	52
QGP1	52
QGP2	52
QGP3	52
QGP0-1	52
QGP1-1	52
QGP2-1	52
QGP3-1	52
R	
Code	page
RFG 442	120
RFG 448	120
RPT 001	83
RQA 410	108
RTF 314	103
RTF 318	103
RTL 110	110
RTL 111	111
RTL 120	110
RTL 141	112
RTL 510	110
RTL 511	111
RTL 520	110
RTL 541	111

RTP 318	102
RUT 002	171
RUT 302	177
S	
Code	page
SAA 001	169
SAA 010	169
SAB 002	167
SAB 002/SF	168
SAB 010	168
SAB 010/SF	168
SAB 020	168
SAC 002	165
SAE 001	167
SAE 002	167
SAE 420	167
SAF 001	166
SAF 001W	166
SAF 002	166
SAF 010	166
SAF 110	166
SAI 010	168
SAL 500	172
SAL 881	123
SAS 880	123
SAU 914	171
SCH 001W	168
SCH 002	168
SCH 010	168
SDA 700	172
SDC 020	36
SDW 201	171
SDW 202	171
SDW 206	171
SGE 001	168
SGG 001	168
SHF 001	170
SIH 001W	167
SIH 002	167
SIH 010	167
SIH 010/Inox	167
SIR 010	169
SMP 750	143

SMP 760	143
SPT 006	77 - 78
SPT 106	77 - 78
SPW 204	171
SPW 210	171
SPW 216	171
SQC 954	173
SQS 954	173
SRD 150	120
SRD 250	120
SRS 150	120
SRS 250	120
SRS 350	120
STA 001	166
STA 001W	166
STA 002	166
STA 010	166
STF 001	169
STH 001	169
STT 010	169
STT 868 H	164
STU 868 H	164
SUP 120	35
SUR 704	170
SUT 734	170
SVK 014	145
SVK 014/C	134
SWB 912	165
SWC 701	176
SWH 005	179
T	
Code	page
TAG 797	174
TCH 072	177
TCH 102	177
THP 868	164
TMS 500	116, 117
TMS 600	116, 117
TMS 700	116, 117
TMT 500	114, 115
TMT 600	114, 115
TMT 700	114, 115

TVG G16	153
TVG G20	153
TVG G25	153
TVG G32	153
TVG G40	153
TVG G50	153
U	
Code	page
UAC 324	181
UAC 328	181
UAL 358	172
UCI 328	82
UCO 318	180
UCO 638	180
UHF 15-1,5	75
UHF 20-2,5	75
UHF 20-3,5	75
UHF 25-3,5	75
UHF 25-6	75
UHF 40-10	75
UHM 15-1,5	75
UHM 20-2,5	75
UHM 20-3,5	75
UHM 25-3,5	75
UHM 25-6	75
UHM 40-10	75
UHN 15-1,5	74
UHN 20-2,5	74
UHN 20-3,5	74
UHN 25-3,5	74
UHN 25-6	74
UHN 40-10	74
UHR 15-1,5	76
UHR 20-2,5	76
UHR 20-3,5	76
UHR 25-3,5	76
UHR 25-6	76
UHR 40-10	76
ULT 328	182
ULT 348	182
ULT 348/51	182
UML 318	181
UPA 798	173
UPC 799	173
UPM 678	112
USB 011	34, 42
USB 485	36, 69
USB M12	146

V	
Code	page
VBR 215-0,25	148
VBR 215-0,4	148
VBR 215-0,63	148
VBR 215-1	148
VBR 215-1,6	148
VBR 215-2,5	148
VBR 215-4	148
VBR 215-6,3	148
VBR 220-4	148
VBR 220-6,3	148
VBR 220-8,6	148
VBR 220-10	148
VBR 225-6,3	148
VBR 225-10	148
VBR 225-16	148
VBR 232-10	148
VBR 232-16	148
VBR 232-25	148
VBR 240-16	148
VBR 240-25	148
VBR 250-25	148
VBR 250-40	148
VBR 315-0,25	149
VBR 315-0,4	149
VBR 315-0,63	149
VBR 315-1	149
VBR 315-1,6	149
VBR 315-2,5	149
VBR 315-4	149
VBR 315-6,3	149
VBR 320-4	149
VBR 320-6,3	149
VBR 320-10	149
VBR 325-6,3	149
VBR 325-10	149
VBR 325-16	149
VBR 332-10	149
VBR 332-16	149
VBR 332-25	149
VBR 340-16	149
VBR 340-25	149
VBR 350-25	149
VBR 350-40	149
VFC 212	132
VFC 213	132
VFC 214	132
VFC 235	132

VFC 237	132	VOBG 312	153
VFC 238	132	VOBG 313	153
VFC 312	132	VOBG 314	153
VFC 314	132	VOBG 315	153
VFC 335	132	VOBG 320	153
VFC 338	132	VOBG 325	153
VFC 412	132	VOBG 332	153
VFC 413	132	VOBG 340	153
VFC 414	132	VOBG 350	153
VFC 435	132	VONF 3100	154
VFC 437	132	VONF 3125	154
VFC 438	132	VONF 3150	154
VFF 3100	141	VONF 315	154
VFF 3125	141	VONF 320	154
VFF 3150	141	VONF 325	154
VFF 340	141	VONF 332	154
VFF 350	141	VONF 340	154
VFF 365	141	VONF 350	154
VFF 380	141	VONF 364	154
VFF 4100	141	VONF 365	154
VFF 4125	141	VONF 379	154
VFF 4150	141	VONF 380	154
VFF 440	141	VORF 3100	155
VFF 450	141	VORF 315	155
VFF 465	141	VORF 320	155
VFF 480	141	VORF 325	155
VFG 320	141	VORF 332	155
VFG 325	141	VORF 340	155
VFG 332	141	VORF 350	155
VFG 340	141	VORF 364	155
VFG 350	141	VORF 379	155
VFG 420	141	VSF 3100	140
VFG 425	141	VSF 3125	140
VFG 432	141	VSF 3150	140
VFG 440	141	VSF 340	140
VFG 450	141	VSF 350	140
VGT 110	135	VSF 365	140
VGT 115	135	VSF 380	140
VGT 120	135	VSG 320	140
VGT 110/R	135	VSG 325	140
VGT 115/R	135	VSG 332	140
VGT 210	135	VSG 340	140
VGT 215	135	VSG 350	140
VGT 220	135	VYG 615-0,25-0,25	150
VGT 210/R	135	VYG 615-0,25-0,4	150
VGT 215/R	135	VYG 615-0,25-0,63	150
VOBG 311	153	VYG 615-0,25-1	150
		VYG 615-0,25-1,3	150

VYG 615-0,25-1,8	150
VYG 615-0,4-0,25	150
VYG 615-0,4-0,4	150
VYG 615-0,4-0,63	150
VYG 615-0,4-1	150
VYG 615-0,4-1,3	150
VYG 615-0,4-1,8	150
VYG 615-0,63-0,25	150
VYG 615-0,63-0,4	150
VYG 615-0,63-0,63	150
VYG 615-0,63-1	150
VYG 615-0,63-1,3	150
VYG 615-0,63-1,8	150
VYG 615-1-0,25	150
VYG 615-1-0,4	150
VYG 615-1-0,63	150
VYG 615-1-1	150
VYG 615-1-1,3	150
VYG 615-1-1,8	150
VYG 615-1,3-0,25	150
VYG 615-1,3-0,4	150
VYG 615-1,3-0,63	150
VYG 615-1,3-1	150
VYG 615-1,3-1,3	150
VYG 615-1,3-1,8	150
VYG 615-1,8-0,25	150
VYG 615-1,8-0,4	150
VYG 615-1,8-0,63	150
VYG 615-1,8-1	150
VYG 615-1,8-1,3	150
VYG 615-1,8-1,8	150
VYG 620 - 0,63 - 1,6	151
VYG 620 - 0,63 - 2,5	151
VYG 620 - 0,63 - 4	151
VYG 620 - 1 - 1,6	151
VYG 620 - 1 - 2,5	151
VYG 620 - 1 - 4	151
VYG 620 - 1,6 - 0,63	151
VYG 620 - 1,6 - 1	151
VYG 620 - 1,6 - 1,6	151
VYG 620 - 1,6 - 2,5	151
VYG 620 - 1,6 - 4	151
VYG 620 - 2,5 - 0,63	151
VYG 620 - 2,5 - 1	151
VYG 620 - 2,5 - 1,6	151
VYG 620 - 2,5 - 2,5	151
VYG 620 - 2,5 - 4	151

VYG 620 - 4 - 0,63	151
VYG 620 - 4 - 1	151
VYG 620 - 4 - 1,6	151
VYG 620 - 4 - 2,5	151
VYG 620 - 4 - 4	151
VYQ 215-1,2	159
VYQ 215-4,8	159
VYQ 220-8	159
VZC 215-PT-B	159
VZC 215-P-B	159
VZC 215-PT-D	159
VZC 215-P-D	159
VZC 220-P-F	159
VZC 220-PT-F	159
VZC 225-PT-G	159

W

Code	page
WEBGARAGE	30
WHS 10K	30
WHS 50K	30
WHS 10K_MAINT	30
WHS 50K_MAINT	30
WHS 10K_MAINT-2	30
WHS 50K_MAINT-2	30
WHS 10K_MAINT-4	30
WHS 50K_MAINT-4	30
WTD 911	44
WTW 900	44

X

Code	page
XCC 602	91
XCC 618	93
XCC 638	93
XCO 428	98
XCS 633	95
XDG 310	139
XDG 310/A	139
XDG 315	139
XDG 315/A	139
XDG 320	139
XDG 320/A	139
XDG 325	139
XDG 325/A	139
XDG 332	139
XDG 332/A	139

XDG 340	139
XDG 340/A	139
XDG 350	139
XDG 350/A	139
XGG 618	82
XLG 315	138
XLG 315/A	138
XLG 320	138
XLG 320/A	138
XLG 325	138
XLG 325/A	138
XLG 332	138
XLG 332/A	138
XLG 341	138
XLG 341/A	138
XLG 351	138
XLG 351/A	138
XPG 658	99
XPT 678	99
XSE 600	96
XSE 602	96
XSS 633	96
XTA 624	105
XTC 638	92
XTE 600	94
XTE 602	94
XTE 611	94
XTE 643	93
XTP 600	95
XTR 628	103
XTT 608	97
XTT 618	97
XTT 618/S1	97
XTU 614	106
XTU 614+XTU 644	107
XTU 618	105
XTU 644	107
XTU 664	108

Y

Code	page
YDG 2100	136
YDG 215	136
YDG 215/A	136
YDG 220	136
YDG 220/A	136
YDG 225	136
YDG 225/A	136

YDG 232	136
YDG 232/A	136
YDG 240	136
YDG 240/A	136
YDG 250	136
YDG 250/A	136
YDG 265	136
YDG 280	136
YDG 215/INOX	137
YDG 215A/INOX	137
YDG 220/INOX	137
YDG 220A/INOX	137
YDG 225/INOX	137
YDG 225A/INOX	137
YDG 232/INOX	137
YDG 232A/INOX	137
YDG 240/INOX	137
YDG 240A/INOX	137
YDG 250/INOX	137
YDG 250A/INOX	137
YHC 700	36
YLC 880	36

Z

Code	page
ZBC 862	35
ZG-AFB	161
ZG-GMA	161
ZG-LF1	161
ZG-NMA	161
ZG-SMA	161
ZG-TF1	161
ZR 2315	150, 151
ZR 2320	150-151, 159
ZR 2325	159
ZRC 658	42

Coster Group offers the best for the efficient management of building systems: from controllers for heating plants to the "made-to-measure Building Management System".

Our approach has always been to integrate technologies and building management to ensure an efficient and at the same time healthy living environment. Without ever sacrificing the simplicity of use of the systems.

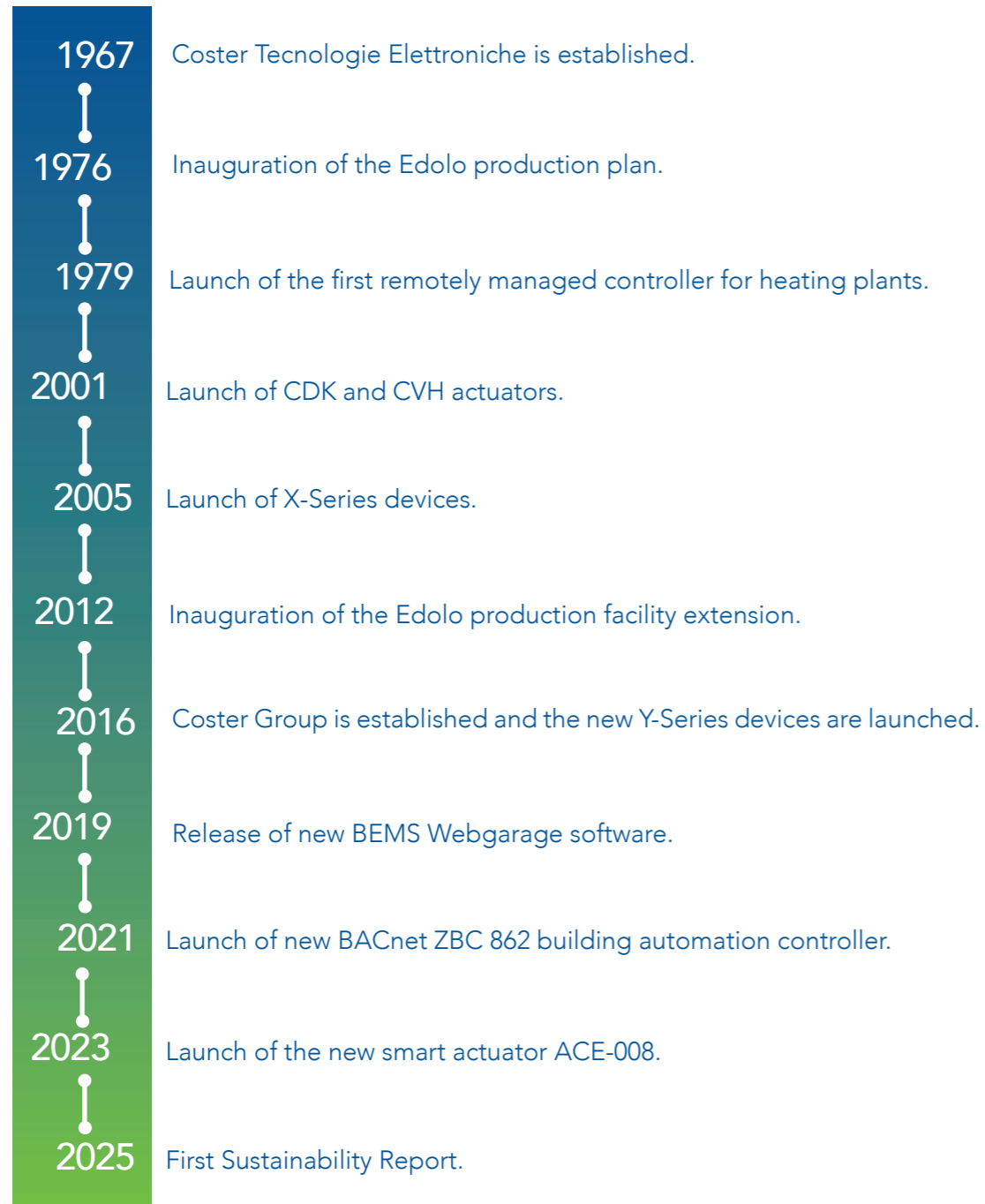

HISTORY



RESEARCH AND DEVELOPMENT.

A specialised team for product innovation.

We proudly devote great energy to research and development of new solutions. Our in-house R&D team enables us to respond quickly to market demand for innovation. We can proudly say that we are among the companies most actively supporting the transition to sustainable and environmentally friendly buildings in accordance with the 2030 Agenda.

SIMPLE SOLUTIONS.

Simplicity of management is a fundamental part of the effectiveness of any project.

"Designing" infinite control schemes with a single device, which can be customised and updated remotely without the need for complex programming techniques. This is the uniqueness of the Coster Group approach, made possible thanks to the CosterCad tool and the WebGarage platform. No unnecessary complexity, no barriers to the adoption of automation.

MADE IN ITALY.

A model factory in Edolo, which manufactures entirely in Italy.

The products developed by our R&D department are assembled and tested directly in our production facility in Edolo (BS), which has embraced the lean production philosophy. Our supply chain privileges selected suppliers and partners, for maximum product reliability (both hardware and software). A strict quality control policy enables us to deliver tested and certified products to our customers, one by one.



WHAT WE DO



In the current energy transition scenario, the private construction industry plays a crucial role. Mere passive upgrading of the building envelope is no longer sufficient: to achieve the climate neutrality targets imposed by Europe, it is essential to equip buildings with a digital, smart 'nervous system'. Building Automation and Control Systems (BACS) are today's most effective lever for ensuring the **Smart Readiness** of buildings, fully complying with the **European Directive EPBD (Energy Performance of Buildings Directive)**.

The adoption of advanced automation systems is not just a technological choice, but a regulatory requirement to raise the energy class of the building. According to the standard **UNI EN ISO 52120-1**, the implementation of advanced control functions can result in switching from basic efficiency classes (C or D) to performance classes (B or A). This leap results in tangible and immediate energy savings, achieved by eliminating waste through active load modulation and dynamic adaptation to actual usage conditions.

True efficiency can only be achieved by the integrated control of **all energy carriers**:

- **Thermal and Gas:** Optimisation of production at the power plant and capillary distribution within the building.
- **Electrical:** Peak absorption management and integration with renewable sources (such as photovoltaics). This vision allows the energy demand and supply of the entire building to be balanced, transforming it from a mere consumer to an active and efficient player in the network.

At the heart of this architecture is the **BEMS (Building Energy Management System)**. Thanks to its ability to exchange data in **real time**, the BEMS not only records historical consumption, but also enables predictive logic and continuous diagnosis. The massive acquisition of data from the field (sensors, meters, actuators) allows in-depth analysis, the detection of instantaneous anomalies and calibration of the system to precise KPIs. With this in mind, data becomes a strategic resource: only by measuring and correcting in real time can design performance be kept constant throughout the building's life cycle.





Transparent integration of heterogeneous and multivendor technology assets (e.g. renewable generation) on standard and open protocols. Energy flows and process KPIs flow into one centralised monitoring platform, equipped with advanced visualisation interfaces for comprehensive remote monitoring.

Holistic, multidisciplinary building system management aimed at maximum efficiency. Smart lighting control, using Constant Light Control (CLC) algorithms and presence detection, works in synergy with the automation of the solar shading, ensuring seamless integration with the system's BEMS architecture.

Optimisation of consumption that extends to the precise regulation of zonal thermo-hygrometric parameters. Interaction with the system is provided by controllers and room terminals designed to combine aesthetic elegance and functional simplicity.

Distributed control and continuous monitoring over a wireless network, drastically reducing the costs and invasiveness of installation. The robustness of the protocol used eliminates range problems, ensuring fast connectivity and control of all utilities.

Advanced management of mechanical systems, from heating and cooling plants to air handling units, using advanced controllers. These devices implement sophisticated energy-saving algorithms, precisely modulating the production and distribution of heating and cooling energy.



WEBGARAGE



WebGarage redefines Building Energy Management System (BEMS) standards as an advanced full-web platform, enabling smart, predictive and fully interoperable management of modern buildings.



Technological Convergence: Integrates plant automation with advanced data analysis, offering a single web interface for total control from any device.



Operational Efficiency and Deployment: Reduces engineering and graphics creation time by up to 30%, supporting all standard protocols and lowering multi-site connection costs via Edge2Cloud architecture.



Semantic Intelligence: Natively based on the Haystack Project standard, organises field data via semantic tagging to ensure maximum intelligibility and interoperability with analytics and third-party systems.



Analytics and KPI Monitoring: Allows the simplified creation of customised dashboards for real-time analysis, facilitating the proactive detection of inefficiencies and anomalies.



Compliance and Sustainability: Designed to respond to the Green Deal and EPBD directives, it practically supports the achievement of energy efficiency and decarbonisation targets for buildings.



Architectural Flexibility: Guarantees total freedom of installation by adapting to any IT infrastructure, whether on embedded controllers, on-premise servers or in the cloud.



Scalable and Unconstrained Model: Offers secure VPN-free remote access, unlimited multi-user management and a perpetual licence model with no recurring fees.

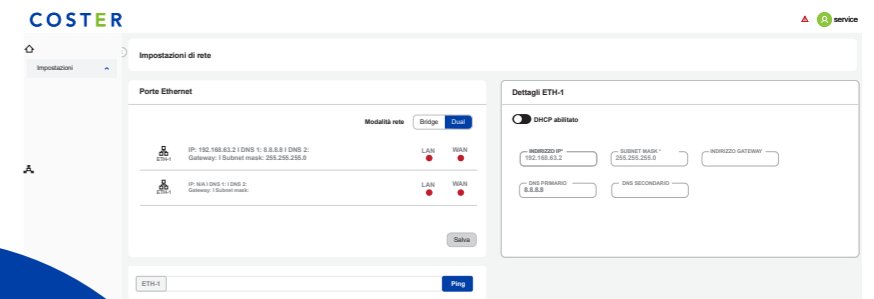
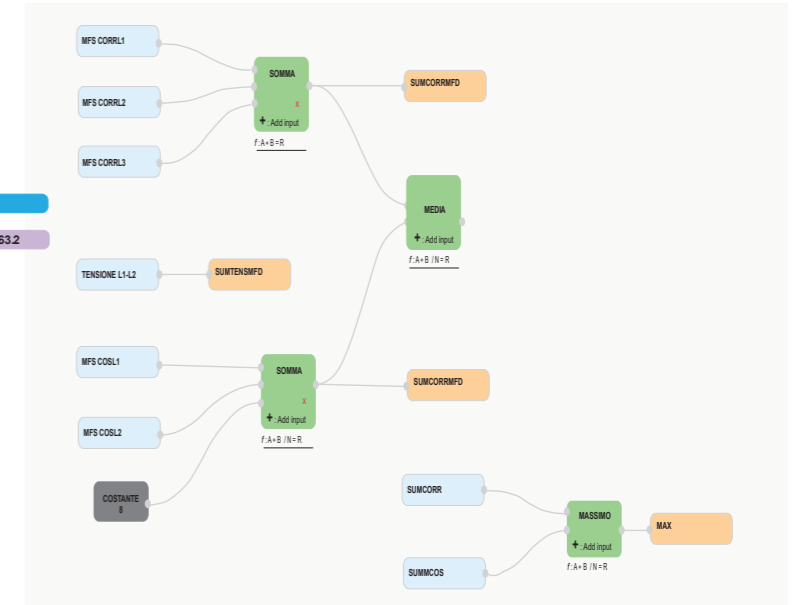
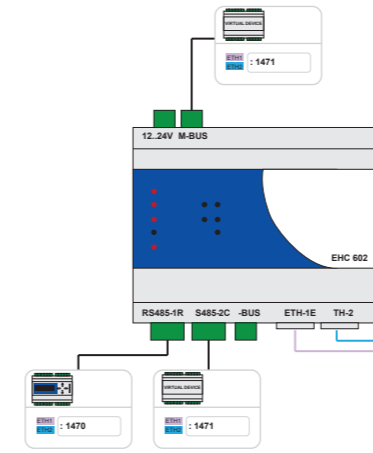

EHC 602 is the advanced Edge Device that eliminates the need for external servers.

- **WebGarage on Board:** Supervision licence included **up to 2000 points**, complete with **dynamic system graphics**.
- **Total Integration:** Centralised management of the main Building Automation protocols.
- **Zero Complexity:** Easy, step-by-step, guided system configuration.
- **Data Flow:** combines and correlates monitoring data via logical blocks, making them immediately available for optimising system control.

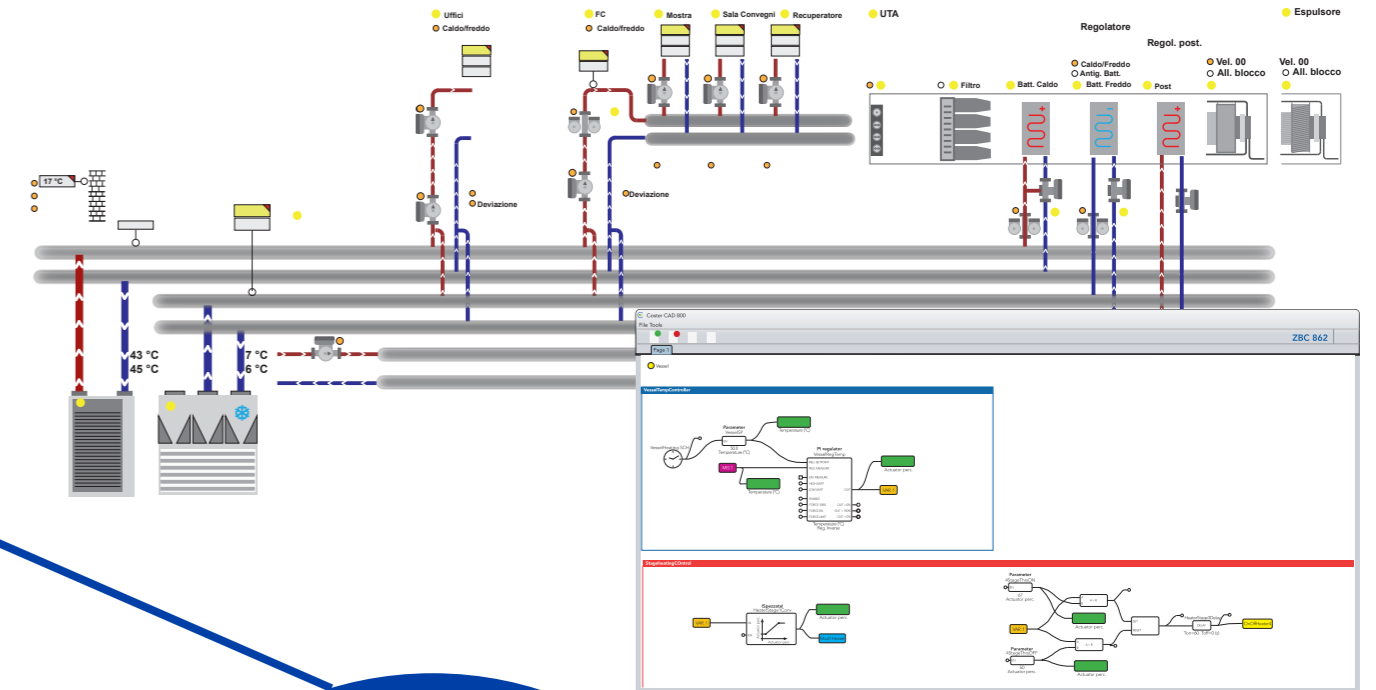

CosterTools is the complete platform for plant automation **HVAC-R**. At its heart, **CosterCAD** combines programming and documentation like no other. **CosterCAD**: the only tool that programs **Coster Y and Z Series** controllers that support both **Modbus** and **BACnet** protocol. Offers simplified **programming, building control logic** by drawing the **system diagram** visually and automatically generating **the Application, the Points List** and the **General Electrical Diagrams**.

CosterTools: Total Control. The full suite also allows you to **configure wireless devices and simulate system logic** on your PC, ensuring speed and accuracy.

Design the system, generate the control.



The ultimate solution for environmental comfort combining control and functional design. The **ZRC 658** (BACnet/MSTP) controller works in perfect synergy with the **PRU 002** room unit to offer complete room management.

- **Multisensor and Interface:** With the PRU 002 the user manages the setpoints and monitors air quality in real time (**Relative Humidity and CO2**).
- **Beyond HVAC:** **ZRC 658** is the flexible solution that extends climate control to integrated **lighting** and **blind control**.
- **Standard Connectivity:** Native BACnet MS/TP integration for maximum interoperability.



The ideal solution for retrofitting and upgrading existing buildings. A **totally wireless** ecosystem using **LoRa 868MHz** technology to ensure extensive coverage and reliability.

Precise monitoring of thermo-hygrometric variables and control of **actuators for radiators** with independent management of **setpoints and time schedulers** for each individual heating element.

By means of a concentrator, the system becomes an integral part of the plant logic, interfacing with the **EHC 602** Edge Device or with the **ZBC 862** and **YLC 880** controllers.





LICENCES AND MAINTENANCE



CW...

WEB GARAGE LICENSES

Software solution with licences sized according to the volume of points managed. The platform ensures full interoperability with the main market protocols, offering complete flexibility in the configuration of point properties: from historical trends to alarm management, visualisation and hourly scheduling.

CWS 100	License 100 controlled and historicised points
CWS 200	License 200 controlled and historicised points
CWS 500	License 500 controlled and historicised points
CWS 01K	License 1000 controlled and historicised points
CWS 02K	License 2000 controlled and historicised points
CWS 05K	License 5000 controlled and historicised points
CWS 10K	License 10000 controlled and historicised points
CWS 50K	License 50000 controlled and historicised points
CWC 100	Add-On License for Server Version. Increases the number of historicised points of the basic license by 100 (Server Version only)
CWC 01K	Add-On License for Server Version. Increases the number of historicised points of the basic license by 1000 (Server Version only)

WHS ...

WEB GARAGE HAYSTACK LICENSES

- **Dedicated Haystack protocol management:** Specific licences for the integration and management of Haystack standards-based points only.
- **Multi-Platform Interoperability:** Enabling communication and data exchange between different WebGarage platforms.
- **Edge connectivity:** Direct connection and integration with EHC 602 Edge Devices.

WHS 10K	HAYSTACK Web Garage Licence 1 year
WHS 50K	HAYSTACK Web Garage Licence 1 year
WHS 10K_MAINT	Maintenance HAYSTACK Web Garage Licence 1 year
WHS 50K_MAINT	Maintenance HAYSTACK Web Garage Licence 1 year
WHS 10K_MAINT-2	Maintenance HAYSTACK Web Garage Licence 2 years
WHS 50K_MAINT-2	Maintenance HAYSTACK Web Garage Licence 2 years
WHS 10K_MAINT-4	Maintenance HAYSTACK Web Garage Licence 4 years
WHS 50K_MAINT-4	Maintenance HAYSTACK Web Garage Licence 4 years



CW..._MAINT

WEB GARAGE LICENSES RENEWAL

Licence renewal to access updates, weather application or connection via Edge2Cloud to the Coster Connect service.

CWS 100_MAINT	Maintenance Licence 100 points 1 year
CWS 200_MAINT	Maintenance Licence 200 points 1 year
CWS 500_MAINT	Maintenance Licence 500 points 1 year
CWS 01K_MAINT	Maintenance Licence 1000 points 1 year
CWS 02K_MAINT	Maintenance Licence 2000 points 1 year
CWS 05K_MAINT	Maintenance Licence 5000 points 1 year
CWS 10K_MAINT	Maintenance Licence 10000 points 1 year
CWS 50K_MAINT	Maintenance Licence 50000 points 1 year

CWS 100_MAINT-2	Maintenance Licence Web Garage 2 years
CWS 200_MAINT-2	Maintenance Licence Web Garage 2 years
CWS 500_MAINT-2	Maintenance Licence Web Garage 2 years
CWS 01K_MAINT-2	Maintenance Licence Web Garage 2 years
CWS 02K_MAINT-2	Maintenance Licence Web Garage 2 years
CWS 05K_MAINT-2	Maintenance Licenza Web Garage 2 anni
CWS 10K_MAINT-2	Maintenance Licence Web Garage 2 years
CWS 50K_MAINT-2	Maintenance Licence Web Garage 2 years

CWS 100_MAINT-4	Maintenance Licence Web Garage 4 years
CWS 200_MAINT-4	Maintenance Licence Web Garage 4 years
CWS 500_MAINT-4	Maintenance Licence Web Garage 4 years
CWS 01K_MAINT-4	Maintenance Licence Web Garage 4 years
CWS 02K_MAINT-4	Maintenance Licence Web Garage 4 years
CWS 05K_MAINT-4	Maintenance Licence Web Garage 4 years
CWS 10K_MAINT-4	Maintenance Licence Web Garage 4 years
CWS 50K_MAINT-4	Maintenance Licence Web Garage 4 years





PROGRAMMABLE CONTROLLERS



PROTOCOLS FOR COMMUNICATION

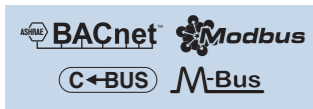

EHC 602

MULTI-PROTOCOL EDGE DEVICE

Optimises communication with YLC / ZBC controllers and can manage and monitor field devices.

It manages three types of system:

- Adjustment with YLC 880 / ZBC 862 + corresponding expanders
- Energy monitoring
- Hybrid or Mixed (control and monitoring)

It is equipped with a web interface that can be reached via an Ethernet port or Wi-Fi. The Versions with embedded webgarage licences up to 2000 points available. It can work as stand-alone unit or in a network.

Communication ports:

- 2 RS 485
- 1 M-Bus
- 1 C-Bus
- 2 Ethernet

12VDC and 24VAC Power supply.

6 module DIN enclosure.

EHC 602	Multi-protocol edge device
EHC 100	Edge device with WebGarage embedded 100 points
EHC 200	Edge device with WebGarage embedded 200 points
EHC 500	Edge device with WebGarage embedded 500 points
EHC 01K	Edge device with WebGarage embedded 1000 points
EHC 02K	Edge device with WebGarage embedded 2000 points

In the systems where it is used, EHC 602 also allows the system to be managed remotely via Ethernet connectivity or 4G routers.

The EHC 602 supports embedded Webgarage licences up to 2000 points^(*) providing the end user with a user-friendly, simple and effective interface.

EHC 602 maximises system performance with Y-series and Z-series controllers and enables management of complex buildings with distributed smart solutions.

^(*) Points licence not included to be dimensioned according to the needs of the system.



PROTOCOLS FOR COMMUNICATION



ZBC 862

MS/TP BACNET CONTROLLER

Controller for HVAC systems programmable via CosterCAD applications. Download the application and firmware locally via USB port and remotely via BACnet protocol. Possible configuration through DSP 120 external display.

Communication ports:

- 1 RS 485 for BACnet MS/TP communication
- 1 RS 485 for expanders
- 1 RS 485 for integration of third-party devices.

INPUT/OUTPUT

- Universal Inputs - UI : 8
- Analogue Outputs - AO: 2
- Digital Outputs - DO: 6

12VDC and 24VAC power supply.

8 module DIN enclosure.

RELATED PRODUCTS

DSP 120	Display for configuration ZBC 862
SUP 120	Front panel support for display
USB 011	USB/RJ11 cable for debug ZBC 862

The ZBC 862 is a freely programmable logic controller capable of controlling HVAC-R systems; the number of inputs and outputs referring to the individual controller can be increased by means of expansion modules.

Main features:

- Running of the adjustment and control application is generated with CosterCAD and/or CosterDiagram.
- Communication with the monitoring system and other devices using the BACnet protocol.
- Optimised application execution time.
- Interoperability with any BACnet system.
- Integration of third-party systems via Modbus protocol



PROTOCOLS FOR COMMUNICATION



YHC 700

MODBUS/TCP NETWORK-MANAGER

Optimises the exchange of data and commands between YLC controllers and the alarm relay, allowing remote access to the supervision system via the Ethernet port using MODBUS/TCP protocol.

It manages three types of system:

- Control with YLC 880
- Energy monitoring
- Hybrid or Mixed (control and monitoring)

Applied to control systems, the YHC allows remote management of the system and remote configuration via webserver through its Ethernet port or via router with SIM connectivity. It can work as stand-alone unit or in a network.

Communication ports:

- 1 RS 485 for Modbus (YLC 880)
- 1 RS 485 for Modbus monitoring
- 1 RS232
- 1 Ethernet

12V DC power supply.

6 module DIN enclosure.



PROTOCOLS FOR COMMUNICATION



YLC 880

PROGRAMMABLE CONTROLLER

Multi-configurable controller for heating, cooling and domestic hot water systems, with the possibility of extending the application logic via CosterDiagram.

The controller allows optimisation of consumption by automatically adapting to climatic variations, implementing management algorithms aimed at maximum attainable performance. The expansion modules allow the number of inputs and outputs referred to the single controller to be increased. The controller also records the behaviour of the system, storing operating parameters and settings, allowing for the analysis and detection of any faults.

Programming is carried out using COSTER CAD software and can be imported into the control unit via SD card.

Communication ports:

- 1 RS 485 for Modbus communication
- 1 RS 485 for expanders
- 1 RS 485 for integration of third-party devices.

INPUT/OUTPUT

- 1-wire sensor⁽¹⁾: 16
- Digital/Analogue Inputs - DI / AI : 8
- Analogue Outputs - AO: 2
- Digital Outputs - DO: 8

12VDC power supply.

8 module DIN enclosure.

RELATED PRODUCTS

SDC 020	SD card
USB 485	Cable required for connection to device

⁽¹⁾ (SIH 001W - STA 001W) are polarised and connectable on a 2-wire bus



PROTOCOLS FOR COMMUNICATION



EST 482

EXPANSION MODULE

Expansion module with 8 universal inputs (digital, analogue and probes⁽¹⁾) capable of communicating with YLC and ZBC controllers.

The expansion module is provided with RS 485 port that makes communication possible with the main controller through Modbus/RTU protocol.

12VDC and 24VAC power supply.

4 module DIN enclosure.



PROTOCOLS FOR COMMUNICATION



ESU 402

EXPANSION MODULE

Expansion module with 4 analogue 0-10V DC outputs which can communicate with the YLC 880 control unit and with ZBC 862. The expansion module is provided with an RS 485 port that makes communication possible with the main controller through Modbus/RTU protocol.

12VDC and 24VAC power supply.

4 module DIN enclosure.



PROTOCOLS FOR COMMUNICATION



ESP 442

EXPANSION MODULE

Expansion module I/O able to communicate with the YLC 880 and ZBC 862 control units.

The expansion module is provided with RS 485 port that makes communication possible with the main controller through Modbus/RTU protocol.

INPUT/OUTPUT

- Sensors⁽²⁾: 2
- Digital/Analogue Inputs - DI / AI: 4
- Digital Outputs - DO: 4

12VDC and 24VAC power supply.

4 module DIN enclosure.

⁽¹⁾ PT1000, NTC 10K, NTC 1K, T5, extended PT 1000, Ni 1000
⁽²⁾ PT1000, NTC 10K, NTC 1K, T5, PT 1000 extended



PROTOCOLS FOR COMMUNICATION



EBR 868

WIRELESS BRIDGE MODULE

Satellite module that allows a wireless connection to be made between the EBR 868C concentrator and one or more compatible expanders. Reduced size 1 DIN module. 12 VDC power supply. ANTENNA INCLUDED.

RELATED PRODUCT

APA 500	SMA antenna extension, length 5 meters
----------------	--



PROTOCOLS FOR COMMUNICATION



EBR 868C

WIRELESS BRIDGE CONCENTRATOR

Wireless concentrator for connecting several EBR 868 units (up to 16) in turn connected to field devices. The combination allows the wireless extension of the communication bus between controllers (Y/Z series) and compatible expanders, via LoRa protocol (868 Mhz). Reduced size 1 DIN module. 12 VDC power supply. ANTENNA INCLUDED.

RELATED PRODUCTS

APA 500	SMA antenna extension, length 5 meters
ANT 868	Upgraded antenna for 868 concentrators
USB 485	Required for direct connection with YLC 880, CSW 868 controllers



PROTOCOLS FOR COMMUNICATION



CSW 868

WIRELESS SENSOR CONCENTRATOR

System module enabling a wireless connection (LoRa 868MHz) with one or more wireless devices (up to 40), such as sensors, actuators and pulse meters:

- THP 868
- PCP 868
- COP 868
- STT 868H
- STU 868H
- ATR 868

Compatible with Y/Z series controllers and gateways EHC 602 / YHC 700. 12V DC power supply. 1 module DIN enclosure. ANTENNA INCLUDED.

RELATED PRODUCTS

APA 500	SMA antenna extension, length 5 meters
ANT 868	Upgraded antenna for 868 concentrators
USB 485	Required for direct connection with YLC 880, CSW 868 controllers



ALM 1210

DIN RAIL POWER SUPPLY UNIT 12V - 10W

Ultra-slim 10 W power supply on DIN mounting. Suitable for installation on DIN mounting TS 35-/7 5. or 15. 1 module DIN enclosure.



ALM 1225

DIN RAIL POWER SUPPLY UNIT 12V - 25W

Ultra-slim 25 W power supply on DIN mounting. Suitable for installation on DIN mounting TS 35-/7 5. or 15. 2 module DIN enclosure.

Electrical panels

Q 88.

Y SERIES ELECTRICAL PANEL WITH 2G CONNECTIVITY

Electrical panels created specifically for Building Automation systems complete with control equipment.

Main component YLC 880 multi-configurable controller.

For other compositions contact your local retailer.

ELECTRICAL PANELS WITH YLC 880 + MDM 232

	SWITCH 230V	ALM 1225	MDM 232	YLC 880	EST 482	ESP 442	ESU 402	PANEL
Q880	1	1	1	1	1	-	-	2 X 18
Q881	1	1	1	1	1	-	1	3 X 18
Q882	1	1	1	1	1	1	1	3 X 18
Q883	1	1	1	1	1	1	2	3 X 18
Q884	1	1	1	1	1	2	2	3 X 18

Q 38.

Y SERIES ELECTRICAL PANEL WITH 4G CONNECTIVITY

Electrical panels created specifically for Building Automation systems complete with control equipment.

Main components of YLC 880 multi-configuration controller and RUT 302 router .

For other compositions contact your local retailer.

ELECTRICAL PANELS WITH YLC 880 + RUT 302

	SWITCH 230V	ALM1225	RUT302	YLC880	EST482	ESP442	ESU402	PANEL
Q380	1	1	1	1	1	-	-	2 X 18
Q381	1	1	1	1	1	-	1	3 X 18
Q382	1	1	1	1	1	1	1	3 X 18
Q383	1	1	1	1	1	1	2	3 X 18
Q384	1	1	1	1	1	2	2	3 X 18

Electrical panels cannot be supplied without devices.





PROTOCOLS FOR COMMUNICATION



ZRC 658

BACNET MS/TP ROOM CONTROL AUTOMATION CONTROLLER

Programmable using CosterCAD application. Download the application and firmware locally via USB port and remotely via BACnet protocol.

Communication ports:

- 1 RS 485 for BACnet MS/TP communication
- 1 RS 485 for user interface and/or expander communication.

INPUT/OUTPUT

- Universal Inputs - UI: 3
- Analogue Outputs - AO: 3
- Digital Outputs - DO: 5

230VAC power supply.
6 module DIN enclosure.

RELATED PRODUCTS

DSP 120	Display for configuration ZBC 862
USB 011	USB/RJ11 cable for debug ZBC 862



PROTOCOLS FOR COMMUNICATION



PRU 002

USER INTERFACE FOR ROOM CONTROL

Colour display with temperature, relative humidity and CO₂ measurement. Intuitive operation with navigation system for Thermo-hygrometric control, blind and light management. 12...24 VAC/VDC power supply. Installation in type 503 electrical boxes or flush with wall

MODELS

PRU 002	User interface for remote control - white
PRU 002/B	User interface for remote control - black



PROTOCOLS FOR COMMUNICATION



LCF 5..

ROOM CONTROLLER

For varied use with power supply 230VAC. The module is provided with an RS 485 port that makes communication possible through the Modbus protocol. For installation in 503 or kaiser (round) electrical boxes

MODELS

LCF 571	Room terminal 5DO 1AO for temperature and relative humidity reading. Hot/cold room unit for fan coils with 5 relay outputs (2 for on/off valve control, 3 for 3-speed fan control), one analogue output and ModBus port..
LCF 572	Environmental terminal 5DO 1AO - for reading temperature, relative humidity and CO ₂ . Hot/cold room unit for fan coils with 5 relay outputs (2 for on/off valve control, 3 for 3-speed fan control), one analogue output and ModBus port.



PROTOCOLS FOR COMMUNICATION



JOY ...

ROOM CONTROLLER

For varied use with power supply 230VAC. The module is provided with an RS 485 port that makes communication possible through the Modbus protocol.

MODELS

JOY 879W	White, hot/cold room unit for 6-way valves with two relay outputs, one 0-10Vdc EC output, ModBus port
JOY 771W	Hot/cold room unit for fan coils with 5 relay outputs (2 for on/off valve control, 3 for 3-speed fan control), ModBus port, white
JOY 363W	White, hot/cold room unit for 2-pipe or 4-pipe fan coils with two relay outputs for on/off valve control, one 0-10Vdc EC output for modulating fan control, ModBus port

Note: Black version available upon request



PROTOCOLS FOR COMMUNICATION



LCF 3..

ROOM CONTROLLER

For varied use with power supply 24VAC. The module is provided with an RS 485 port that makes communication possible through the Modbus protocol.

MODELS

LCF 363W	Hot/cold unit for 2- or 4-pipe fan coils with 3 analogue outputs 0...10 V DC (EC fan, heating valve and cooling valve), 2 digital outputs for E/I switching, ModBus port, white
LCF 364W	Hot/cold unit for 2- or 4-pipe fan coils with 2 analogue outputs 0...10 V DC (heating and cooling) and 3 relay outputs for controlling a 3-stage fan, ModBus port, white
LCF 771W	Hot/cold unit for fan coils with 5 relay outputs (2 for on/off valve control, 3 for 3-speed fan control), ModBus port, white



WTD 911

WEEKLY DIGITAL CHRONOTHERMOSTAT

Weekly digital chronothermostat for room temperature control at three levels (Comfort - Reduced - Off/Still). On-Off control, for activating loads (e.g. boilers, heat pumps, valves, circulators, etc.) in heating/cooling systems for domestic premises or offices.



WTW 900

WIRELESS DIGITAL WEEKLY CHRONOTHERMOSTAT

Consists of:

WTB 900 Battery-powered wireless-controlled weekly chronothermostat for room temperature control on three levels: Comfort, Reduced or Off/Frost protection.

WTR 900 One-channel wireless concentrator with On-Off control, for activating loads (e.g. boilers, heat pumps, valves, circulators, etc.) in heating/cooling systems for homes or offices.

Lighting control

Inside the building, centralised and efficient lighting control will be increasingly important. The reasons are simple:

- Reduction of energy consumption, considerable reduction of energy consumption: adaptive control algorithms identify available daylight to ensure ideal lighting conditions and increase occupant well-being. Room presence control allows for the implementation of scenarios to reduce and/or switch off lighting fixtures when not needed by the occupants.
- Reduced maintenance effort, operating parameters such as fault conditions, operating hours and energy consumption of each individual device can be accessed centrally.
- Synergies through integration with other building automation and management systems. Integration with HVAC control systems completes the COSTER building automation solution.



PROTOCOLS FOR COMMUNICATION



BDL 0..

DALI GATEWAY TO BACNET IP AND BACNET MS/TP

DALI gateway to BACnet IP or BACnet MS/TP with configuration via integrated webserver. All BDL models ... are equipped with an integrated DALI bus power supply.

BDL 001 and BDL 002 can supply the DALI channel with a guaranteed supply current of 230 mA, while BDL 004 can supply 116 mA per DALI channel.

BDL 001	DALI Gateway to BACNET IP 1-channel/DALI port
BDL 002	DALI gateway to BACNET IP 1 to 2 channels/DALI ports
BDL 004	DALI gateway to BACNET IP 1 to 4 channels/DALI ports



PROTOCOLS FOR COMMUNICATION



PDA 004

DALI CHANNEL AUXILIARY POWER SUPPLY

Power supplies are used to boost power for up to four DALI channels/ports. For each channel, the power supplies provide a guaranteed supply current of 116 mA to power the devices connected to the DALI channel.

If the DALI devices connected to the channel consume more than 116 mA, two DALI outputs of the power supplies can be used in parallel, resulting in a guaranteed supply current of 232 mA (maximum supply current of 250 mA).



PROTOCOLS
FOR COMMUNICATION



PDD 001

LIGHT AND PRESENCE SENSOR FOR FALSE CEILING INSTALLATION

Presence detection via passive IR element. Operating range of the light sensor: 5...2000 lx. Detection height up to 4 metres.

Operating indicator LED:

Suitable for indoor applications: Classrooms, Conference Rooms, Corridors, Open space. Can be integrated into lighting and building management systems supporting DALI-2 sensors.



PROTOCOLS
FOR COMMUNICATION



PDD 002

LIGHT AND PRESENCE SENSOR FOR FALSE CEILING INSTALLATION

Presence detection via passive IR element.

Suitable for indoor applications: individual offices, open plan offices, classrooms, conference rooms and corridors. Mounting height: 2...5 metres.

Adapter for ceiling installation. Quick and easy installation via wire springs. Power supply via DALI bus (no mains connection required). Presence detection angle adjustable from 40 to 90 thanks to integrated shutters. Can be integrated into lighting and building management systems supporting DALI-2 sensors.



PROTOCOLS
FOR COMMUNICATION



PDD 003

LIGHT AND MOTION SENSOR FOR CEILING INSTALLATION

Motion detection via passive IR element. Operating range of the light sensor: 5...2000 lx. Detection height up to 4 metres.

Area of application: Underground parking, multi-storey car park, storage and parking areas, stairs.

Protection class IP 54.

Power supply via DALI bus (no mains connection required) Several sensors can be connected to the same DALI line.

Can be integrated into lighting and building management systems supporting DALI-2 sensors.



PROTOCOLS
FOR COMMUNICATION



PDD 004

LIGHT AND MOTION SENSOR FOR CEILING INSTALLATION

Motion detection via passive IR element

Operating range of the light sensor: 5...2000 lx (measured on the sensor) Detection height up to 14 metres (detection range optimised for elevated heights).

Area of application: Industry, high bay warehouses, suitable for high installation heights, production halls, entrance halls.

Protection class IP 54.

Power supply via DALI bus (no mains connection required) Several sensors can be connected to the same DALI line.

Can be integrated into lighting and building management systems supporting DALI-2 sensors.



PROTOCOLS
FOR COMMUNICATION



PDD 005

LIGHT AND MOTION SENSOR FOR FALSE CEILING INSTALLATION

Motion detection via passive IR element Light sensor operating range: 5...2000 lx (measured at sensor) Detection height up to 17 metres.

Area of application: Industry, high bay warehouses, suitable for high installation heights, production halls, entrance halls

Protection class IP 65 (under installation conditions)

Power supply via DALI bus (no mains connection required)

Multiple sensors can be connected to the same DALI line.

Can be integrated into lighting and building management systems supporting DALI-2 sensors.

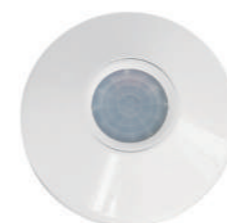

PDS 001

PRESENCE AND BRIGHTNESS SENSOR WITH PHYSICAL CONTACT

Suitable for high installation heights: Industry, production departments, halls.

3 to 10 m: detection of people's movement.

3 to 13 m: detection of vehicle movement (e.g. forklift truck).

Adjustable switch-off delay: From 30 seconds to 20 minutes.



PROTOCOLS
FOR COMMUNICATION



PBD 400

DALI PUSH BUTTON COUPLER

4 floating inputs

Standard pushbuttons/switches can be used.

Suitable for installation in flush-mounted boxes in individual offices, classrooms and conference rooms.

Power supply via DALI bus (no mains connection required)

Can be integrated into lighting and building management systems supporting

DALI-2 sensors.



With the Edge Device EHC ..., Coster Group **redefines building management**, bringing the intelligence of BEMS directly to the premises.

The device is at the heart of a distributed system that ensures total interoperability (**standard protocols and native Haystack**) and optimised multisite management.

The strength of the ecosystem is managed connectivity: thanks to the **Coster Connect service**, EHC ... provides remote access to the system without burdening the customer's network infrastructure.. **By providing a SIM card with a private APN**, Coster ensures a stable, secure and always-active connection, lowering IT management costs.

EHC 602 supports **WebGarage** licences **up to 2000 points** and ensures compliance with **Cyber Security directives**. In synergy with the **Y and Z series controllers**, it offers an intuitive interface for complete, real-time building control.





GPC 642 CONFIGURABLE CONTROLLER



PROTOCOLLI DI COMUNICAZIONE



GPC 642

COMPACT CONTROLLER WITH INCORPORATED 4G MODEM

Compact controller with pre-loaded applications. 6-module DIN device, with built-in 4G communication engine. Control and remote management with Climaoffice and WebGarage.

Communication ports:

- 1 RS 485 for Modbus communication
- 1 M-bus up to 5 devices

INPUT/OUTPUT

- Universal inputs - UI: 6
- Analogue Outputs - AO: 1
- Digital Outputs - DO: 4

12VDC and 24VAC power supply. 6 module DIN enclosure.

The GPC 642 is a compact controller with preconfigured logic and integrated 4G connectivity; it provides a predefined set of applications, suitable for the simplest and most common cases of control and metering systems.

For some applications, it is possible to expand the system via expansion modules.

GPC 642 acquires the wireless sensors via CSW 868. The main functionalities of the GPC 642 are:

- Execution of adjustment and control application.
- Remote device configuration and parameterisation through 4G engine or locally via the micro USB port.
- Acquisition of metering data from connected M-BUS devices
- Communication with the supervision system via the Modbus protocol.

The use of GPC 642 allows a flexible and intelligent management of resources, aimed at exploiting the potential offered by each resource in the field.

QGP.

ELECTRICAL PANELS WITH GPC 642

For other compositions contact your local retailer.

ELECTRICAL PANEL with GPC 642

	Switch 230V	ALM 1225	GPC 642	ESP 442	ESU 402	CSW 868	PANEL
QGP0				-	-		1 X 18
QGP1				1	-		
QGP2				-	1		2 X 18
QGP3				1	1		
QGP0-1	1	1	1	-	-		1 X 18
QGP1-1				1	-	1	
QGP2-1				-	1		2 X 18
QGP3-1				1	1		

Synoptics for thermal power plant control

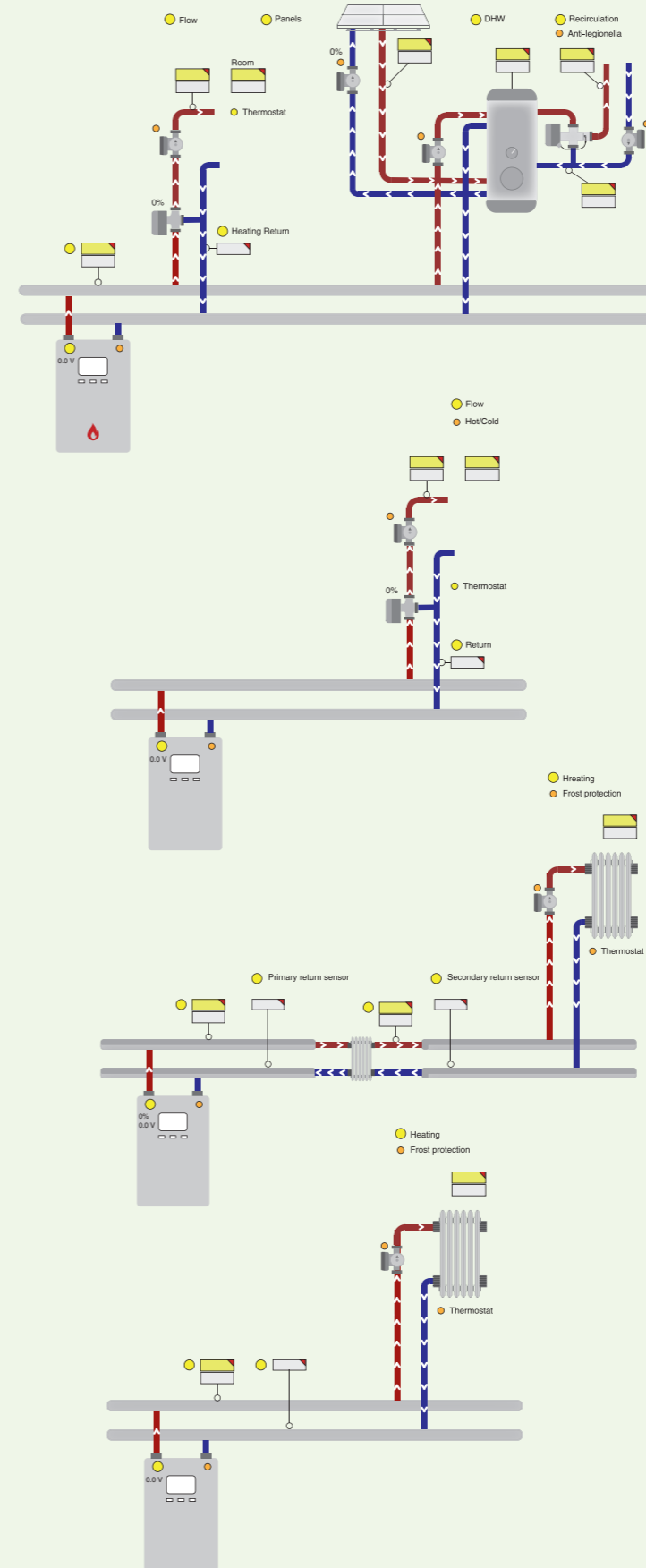

Climate control of the system in heating mode with DHW.

This application allows climate control, intervening directly on the flow temperature of the system, according to the external climate conditions and the room temperature. It allows you to manage the domestic hot water circuit with or without the aid of renewable energy sources. Requires an additional ESP 442 expansion module.

Mixed Climate

This application allows climate control, intervening directly on the flow temperature of the system, according to the external climate conditions and the room temperature. The On/Off control of a hot/cold generator and a mixing valve with 0-10 V or three points control are managed.

ZDV boiler in temperature with exchanger

This application manages a climate heating circuit and a boiler with 0-10V temperature command.

ZDV boiler in temperature

This application manages a climate heating circuit and a boiler with 0-10V temperature command.

ZDV boiler in Power

This application manages a climate heating circuit and a boiler with 0-10V power control.

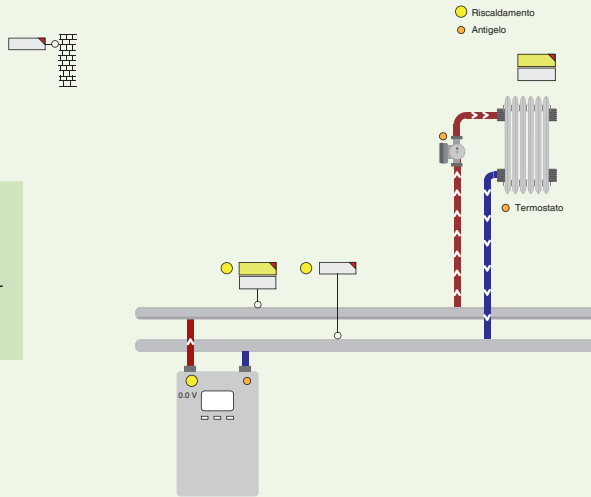

Power boiler ZDV with exchanger

This application manages a climate heating circuit and a boiler with 0-10V power control.

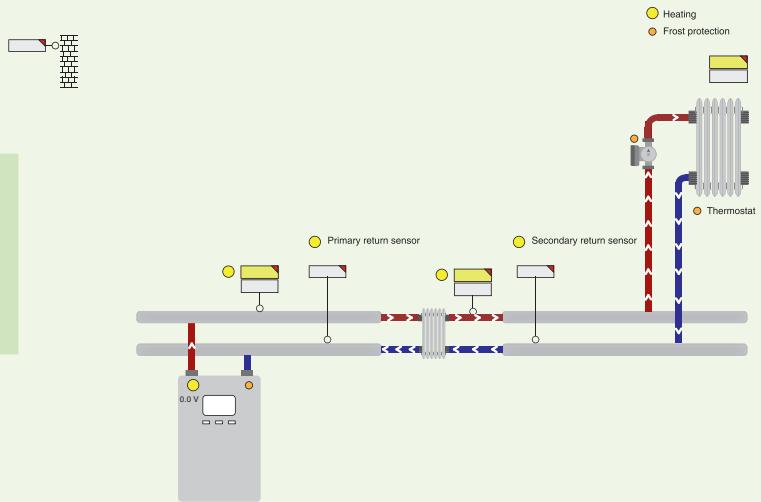

District heating application

Suitable for secondary circuit temperature control of the exchangers supplying the district heating substations.

● ● Overtime

● Users

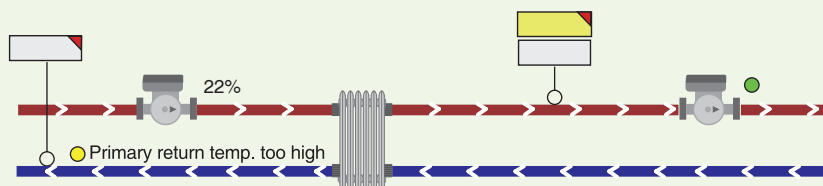



SYSTEM ARCHITECTURE

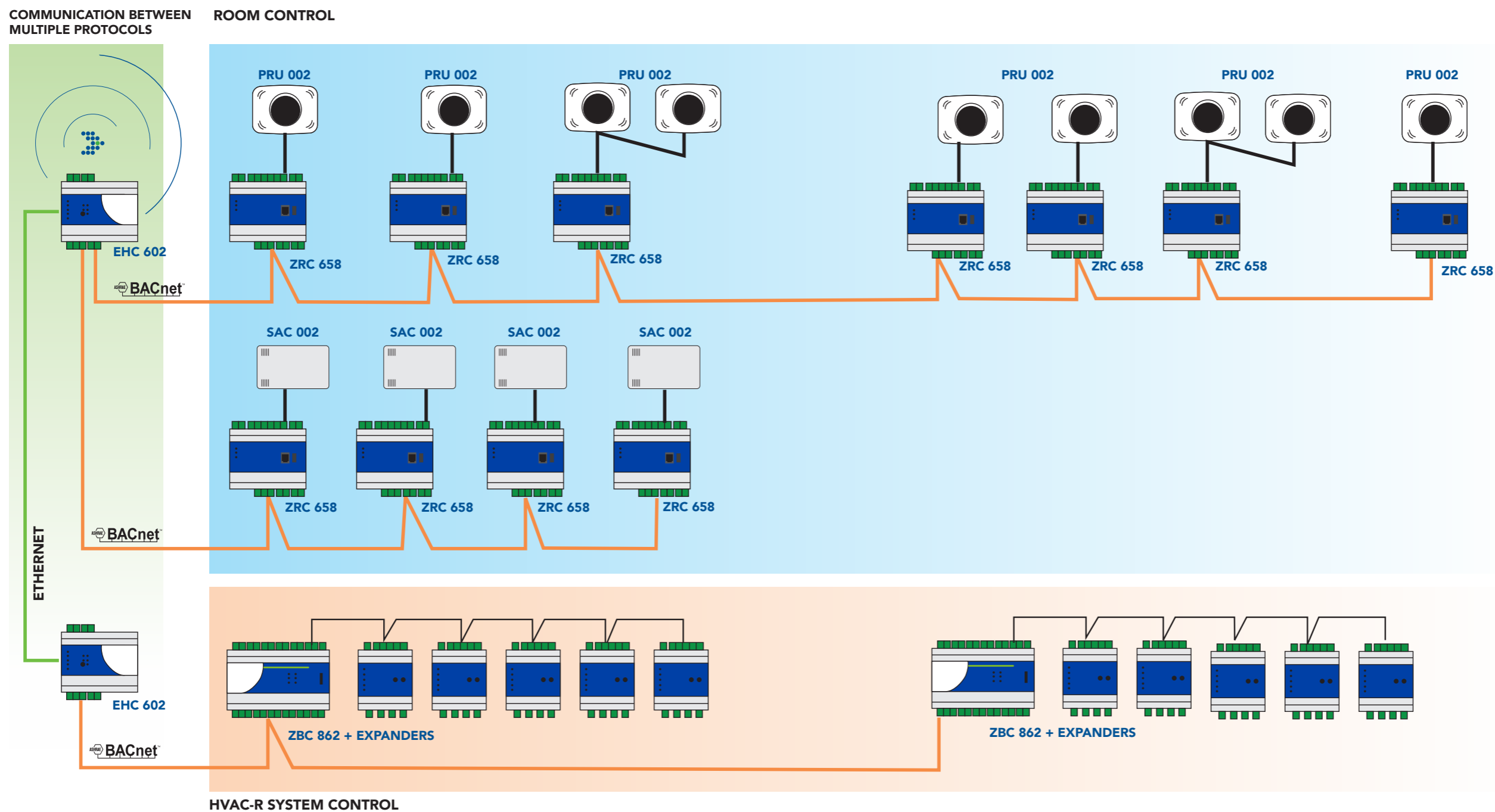

Native BACnet Ecosystem: Scalability, Comfort and Energy Efficiency.

Architecture based on the standard BACnet protocol, designed for maximum flexibility and scalability. The system ensures a continuous, two-way dialogue between energy production (heating plants, AHUs) and room management (fan coils, radiant floor, valves, etc.), adapting dynamically to the actual needs of the building. Thanks to full interoperability and optimised data exchange, our solution achieves Class A according to BACS UNI EN ISO 52120-1:2022, maximising energy savings and living comfort.

The core of the system is divided into three strategic levels:

- Room Control: The **ZRC 685** controller manages zone logic via built-in I/Os. It interfaces with the user by means of two advanced devices that detect Temperature, Relative Humidity and CO2: the PRU 002 (advanced interface with colour touch display) and the SAC 002 (blind interface with essential design).

- Plant Management: The **ZBC 862** controller is designed to control power plants. Despite its ability to handle complex logic, programming is made straightforward by the CosterCAD environment, the intuitive tool that simplifies system configuration.
- Edge Supervision: The Edge Device **EHC 602** optimises IP communication and natively integrates the WebGarage platform. This provides a complete on-premises BEMS (Building Energy Management System), accessible via the web directly from the electrical panel, eliminating the need for dedicated servers or fixed supervision PCs.

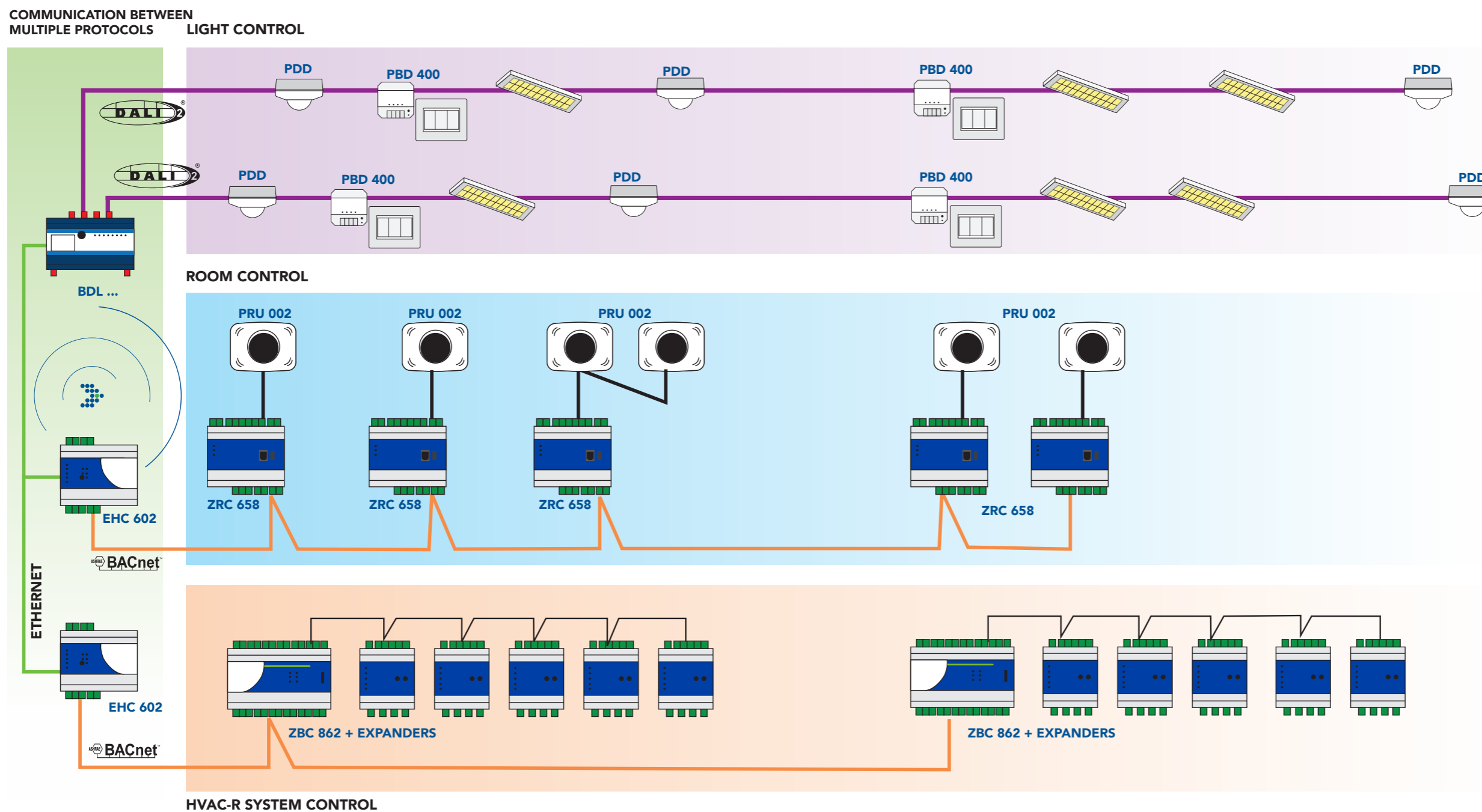

From Climate Control to Integrated Lighting.

The system evolves beyond mere climate control by integrating DALI/DALI-2 protocols via dedicated gateways, bringing light fittings and presence sensors directly onto the BACnet network. This convergence allows DALI sensors to actively interact with the ZRC 658 controller, signalling the room's occupancy status to activate Comfort mode only when really needed, optimising energy consumption. The advanced PRU 002 interface complements local management by becoming a true command centre: in addition to monitoring T, RH and CO2, the touch display allows the user to control lights and activate customised scenarios.

The system is completed by the Edge Device EHC 602, which, thanks to the embedded WebGarage platform, acts as a 'serverless' BEMS directly at the electrical panel. The web interface allows integrated monitoring of climate and lighting via customisable graphical synoptics designed to make operation and user control as simple as possible

COMMUNICATION BETWEEN MULTIPLE PROTOCOLS

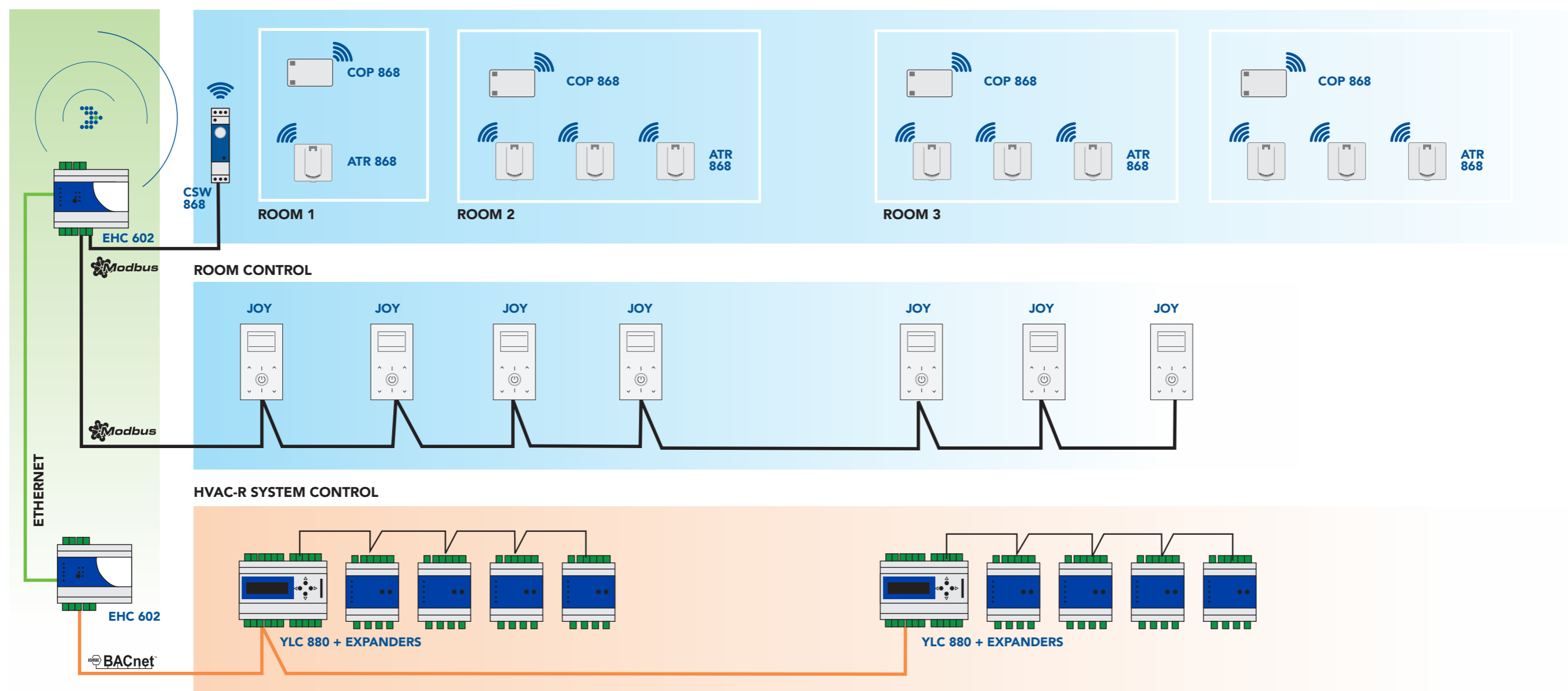

Integrated Modbus Architecture: Optimisation from Power Plant to Environment.

The architecture based on the standard Modbus protocol offers a transparent and scalable solution, capable of connecting the entire system into a single communicating ecosystem. From generation in the heating plant to the individual heating body. The system provides the active control required by current regulations for energy optimisation.

- YLC 880 – The heart of central management This Modbus controller is designed for maximum flexibility. Thanks to its expandable nature and integrated display, the YLC 880 drastically simplifies configuration and commissioning. It is the ideal solution for handling complex plant logics and the distribution of fluids to the various circuits, adapting to any type of application.
- JOY – Distributed intelligence in the room. The JOY room controller combines user interface and control logic. Equipped with integrated inputs/outputs, it enables comprehensive management of room comfort The

strong point. lies in the pre-loaded apps (model-specific), which reduce programming time making the device 'ready to use' for zone regulation.

- Wireless ecosystem (THP 868, COP 868, ATR 868) - Total connectivity For maximum efficiency without structural constraints, the system uses an advanced wireless suite:
 - Monitoring THP 868 and COP 868 probes for precise measurement of thermo-hygrometric variables.
 - Actuation: ATR 868 actuators for direct control on radiators. This wireless layer communicates in real time with the central system (interfacing directly with YLC/ZBC controllers or via Edge Device), allowing production to be modulated according to the actual demand of individual rooms. All this can be perfectly integrated into the WebGarage supervision platform for both Modbus and BACnet networks.

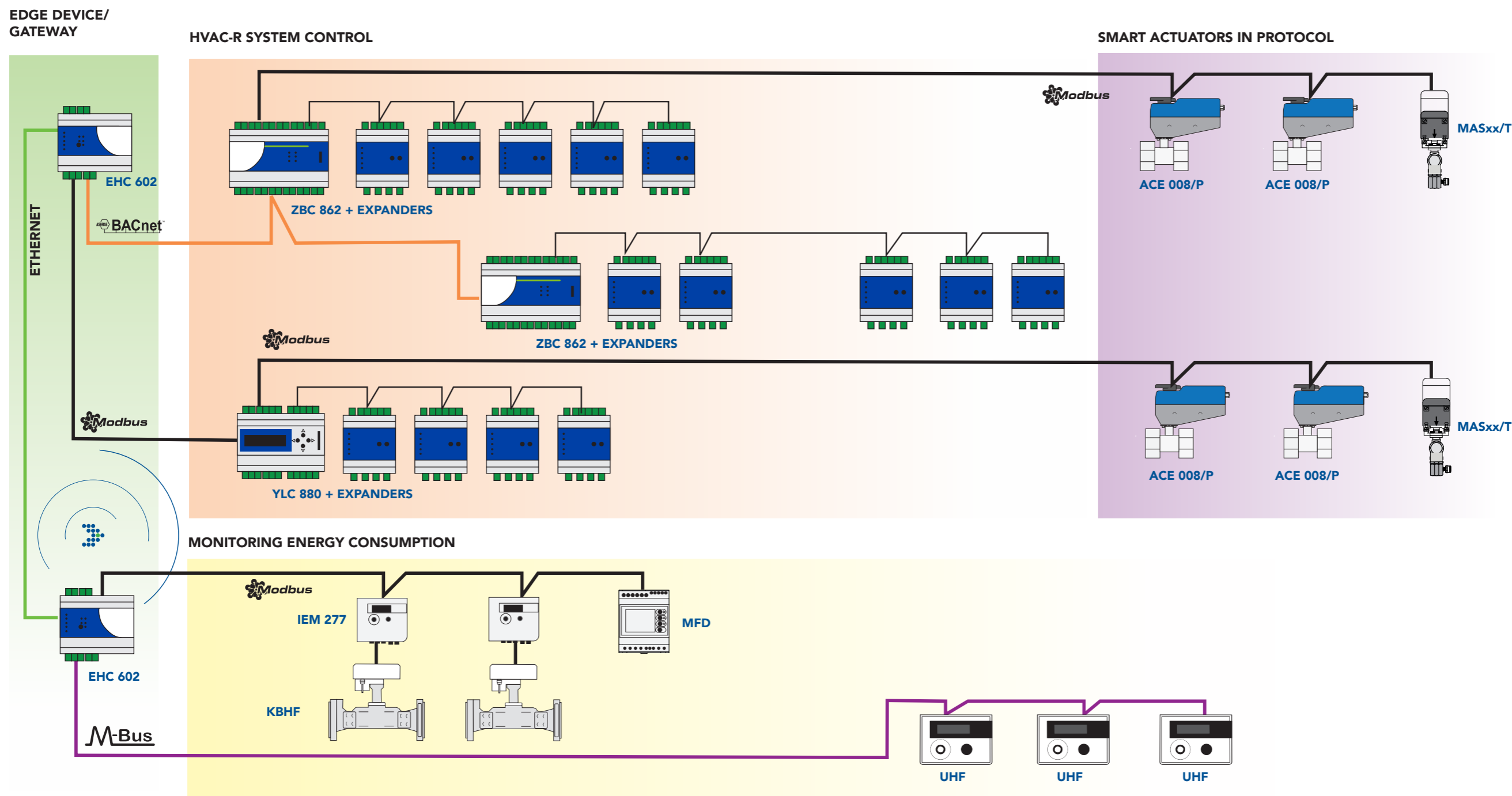

Total Interoperability: Hybrid Management and Integrated Energy Monitoring.

Thanks to the computing power and versatility of the Edge Device EHC 602, architectures can be flexible and cost-effective. This device not only acts as a supervisor, but also as a real universal gateway, enabling the creation of hybrid systems in which different protocols coexist and dialogue under one central intelligence.

- Coexistence of the Y and Z Series under one supervisor, the Edge Device EHC 602 breaks down barriers between different generations or types of controllers. Through a single access point, it is possible to simultaneously manage the Y and Z Series controllers. This unified architecture allows you to exploit the native applications of both controllers, specifically developed to maximise environmental comfort while drastically reducing energy waste through predictive optimisation algorithms.
- Reduced installation costs: controllers allow direct integration of third-party devices and, most importantly, native management of Coster smart actuators via bus protocol.

- Technical Advantage: Eliminating the need for complex point-to-point wiring and additional I/O modules, the actuator receives commands and transmits diagnostic feedback directly via digital communication.
- Applications: This technology is used effectively both for the fine-tuning of system circuits and critical management of the production and distribution of Domestic Hot Water (DHW), ensuring accuracy and speed of response

- Advanced Metering: Thermal and Electrical. A must for a modern BACS system is accurate consumption measurement. The system natively integrates energy metering, eliminating the need for parallel infrastructure:
 - Protocol flexibility: Thanks to a dedicated physical port, the hardware directly handles both the Modbus protocol and the M-Bus standard (Meter-Bus), specifically for meter reading.
 - Total Management: Data can be acquired from both heat energy meters (hot/cold) and electricity network analysers. These data are historicised and made available for efficiency analyses
 - Cost allocation, centralising all energy information in the same device that manages regulation.

WEBGARAGE

HVAC-R SYSTEM CONTROL

MONITORING ENERGY CONSUMPTION

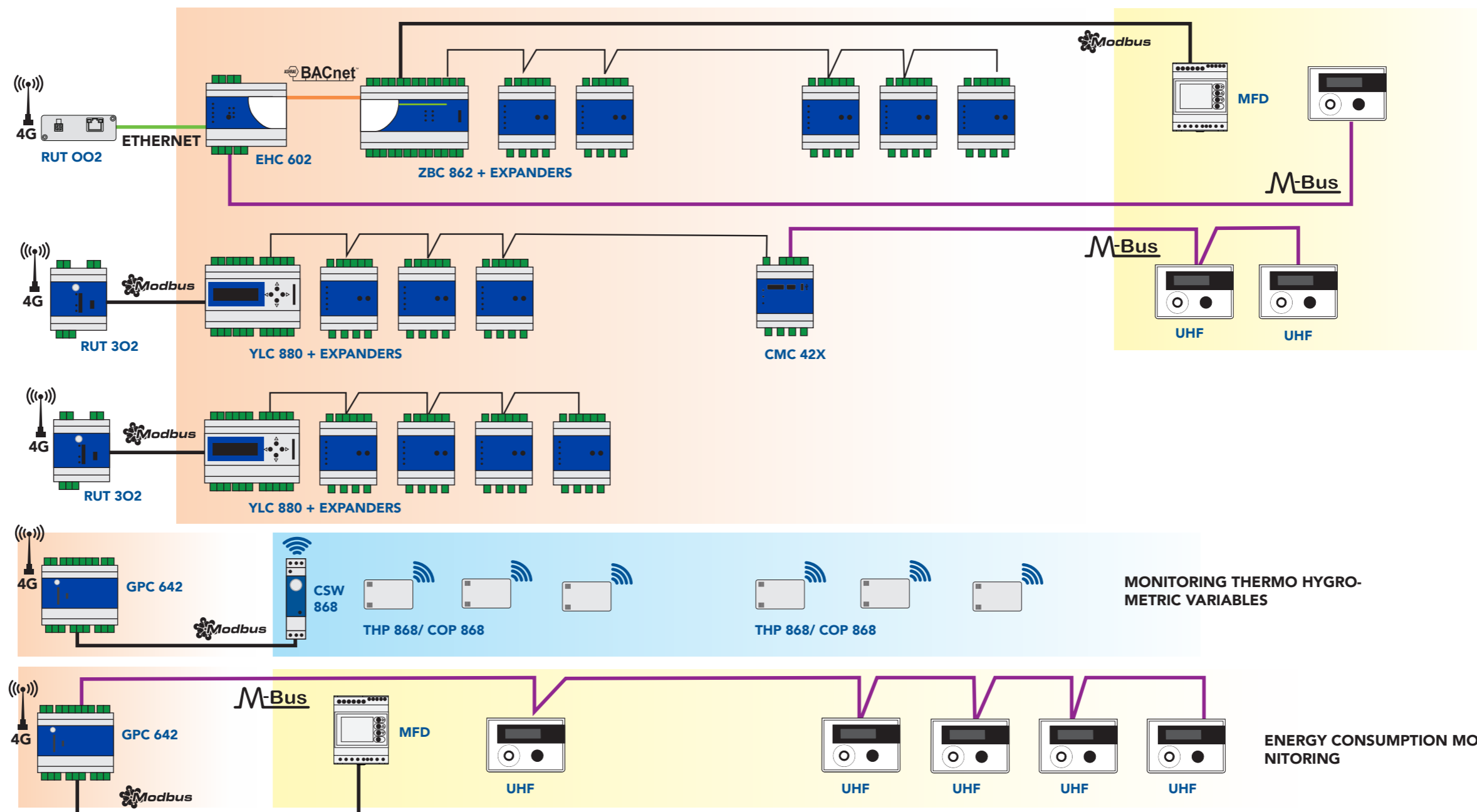

Distributed Architecture and Secure Remote Management: Scalability from Small to Medium Plants.

The approach based on a distributed architecture, with a dedicated controller for each system, is the ideal solution to cover the needs of a diverse installed base, ranging from medium-sized power plants to small remote systems. This structure is natively designed to support complex remote management networks, ensuring full compliance with the most stringent cybersecurity criteria for data and infrastructure protection. Management is centralised in a single platform, WebGarage, which redefines the concept of supervision:

- Unified Management: Full control of alarms and time schedules (scheduler) for each site.
- Energy monitoring: Acquisition and analysis of both thermal and electrical data.
- Operational Efficiency: Possibility of performing mass operations (updates or setpoint changes on several plants simultaneously) and configuration of multi-site Dashboards for immediate overview (benchmarking between plants).

This proposal is highly flexible and comes in three main configurations depending on requirements:

- Haystack Advanced Integration (EHC 602 + ZBC 862), this configuration provides for communication between two WebGarage instances: one in the cloud (remote) and one on-premise integrated in the Edge Device EHC 602. The EHC manages the ZBC 862 controllers locally and projects the screen and data to the central supervisor using the standard Project Haystack protocol. It is the top-of-the-line solution for data semantics and update speed.
- Modbus Transparent Connectivity (RUT 302 + YLC 880) Robust and essential solution using the RUT 302 industrial router. This device acts as a secure gateway for Modbus management of YLC 880 controllers. It allows full remote maintenance and timely retrieval of all energy and operating data, ensuring a reliable and secure connection.
- Compact All-in-One Solution (GPC 642) Ideal for small systems where space and budget are critical factors. The GPC 642 is a compact controller that combines control logic with native data connectivity. Despite its small size, it makes no compromises: it manages the system and directly integrates the variables for energy and environmental monitoring, acting as an autonomous node in the remote management network.

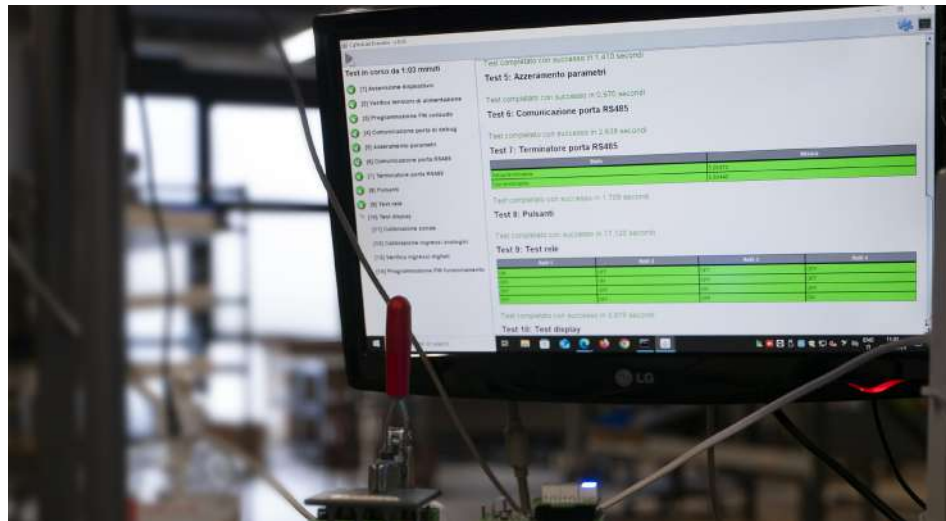



MONITORING SYSTEM

The importance of analysis, from monitoring to supervision

There is an increasing need for dedicated systems for measuring consumption and environmental parameters, in the industrial, services, managerial and public sectors. We build systems that meet legal standards with rigorous energy measurements, direct metering and distribution. Can be used in any private or public building. Our offer includes monitoring of electricity, heat, water and all the main environmental parameters necessary for the evolved management of buildings and production processes: temperature, humidity, pressure, CO2 and air quality.

The use of an open communication protocol that can be easily integrated in third party systems makes our Monitoring solution flexible, scalable and easy to consult.



PROTOCOLS FOR COMMUNICATION



EHC 602

MULTIPROTOCOL EDGE DEVICE

In monitoring applications, it is capable of acquiring field devices. It is equipped with a web interface that can be reached via an Ethernet port or Wi-Fi. The Versions with embedded webgarage licences up to 2000 points are available. It can work as stand-alone unit or in a network.

Communication ports:

- 2 RS 485
- 1 M-Bus
- 1 C-Bus
- 2 Ethernet

12VDC and 24VAC power supply.
6 module DIN enclosure.

EHC 602	Multi-protocol edge device
EHC 100	Edge device with WebGarage embedded 100 points
EHC 200	Edge device with WebGarage embedded 200 points
EHC 500	Edge device with WebGarage embedded 500 points
EHC 01K	Edge device with WebGarage embedded 1000 points
EHC 02K	Edge device with WebGarage embedded 2000 points



PROTOCOLS FOR COMMUNICATION



EST 482

EXPANSION MODULE

Expansion module with 8 universal inputs (digital, analogue and probes(1)) capable of communicating with YLC and ZBC controllers. The expansion module is provided with RS 485 port that makes communication possible with the main controller through Modbus/RTU protocol.

12VDC and 24VAC power supply.
4 module DIN enclosure.



PROTOCOLS FOR COMMUNICATION



BRG 868

EXPANSION MODULE

Satellite module to create a wireless connection between the BRG 868C concentrator and one or more compatible field devices.

12VDC power supply
ANTENNA INCLUDED.
1 module DIN enclosure.

RELATED PRODUCT

APA 500	SMA antenna extension, length 5 meters
---------	--



PROTOCOLS FOR COMMUNICATION



BRG 868C

WIRELESS BRIDGE CONCENTRATOR

Wireless concentrator for connecting several BRG 868 units (up to 16) in turn connected to field devices.

The pairing allows the wireless extension of the communication bus for compatible monitoring devices, via LoRa protocol (868 Mhz).

12VDC power supply
ANTENNA INCLUDED.
4 module DIN enclosure.

RELATED PRODUCTS

APA 500	SMA antenna extension, length 5 meters
ANT 868	Upgraded antenna for 868 concentrators
USB 485	Required for direct connection with YLC 880, CSW 868 controllers

(1) PT1000, NTC 10K, NTC 1K, T5, PT 1000 extended, Ni 1000, Potentiometer



PROTOCOLS FOR COMMUNICATION



CSW 868

WIRELESS SENSORS CONCENTRATOR

System module enabling wireless connection with one or more radio devices (up to 40):

- THP 868
- PCP 868
- COP 868
- STT 868H
- STU 868H
- ATR 868

It provides two-way communication with wireless field devices. Can be paired with Y... and Z... series controllers, or with EHC 602 or YHC 700.

12VDC power supply
1 module DIN enclosure.
ANTENNA INCLUDED.

RELATED PRODUCTS

APA 500	SMA antenna extension, length 5 meters
ANT 868	Upgraded antenna for 868 concentrators



PCP 868

WIRELESS PULSE METER

PCP 868 can acquire and transmit to the CSW 868 concentrator the values of two pulse inputs acquired from the room they are installed in. Battery powered.



GSP 485

MODBUS PULSE METER

Device for reading two meters with pulse output. The device allows the user to query the tools connected to it, using the RS 485 interface.
12 VDC power supply.
3 module DIN enclosure.

RELATED PRODUCTS

EHC 602	Edge Device BACnet and Modbus multi protocol
YHC 700	Modbus/TCP Network-Manager



PROTOCOLS FOR COMMUNICATION



CMC 422 - 428

M-BUS/MODBUS - M-BUS/C-BUS PROTOCOL CONVERTER

M-Bus/ModBus or M-Bus/C-Bus protocol converter for acquiring thermal energy meter data (up to 5 devices queried).
4 module DIN enclosure.

		Power supply
CMC 422	Mbus/modbus Converter up to 5 devices	12...24 VAC/VDC
CMC 428	Mbus/modbus Converter up to 5 devices	230 VAC

RELATED PRODUCT

MWM 000	M-Bus/Wireless M-Bus converter
----------------	--------------------------------



MWM 000

M-BUS/WIRELESS M-BUS CONVERTER

Wireless M-Bus to M-Bus gateway for 5 devices.
It can only be used with CMC 422 and CMC 428.



CMC 328

M-BUS TO C-BUS CONVERTER

Connection of devices equipped with M-Bus (e.g.: heat meter) to the C-Bus line.

CMC 328	M-Bus to C-Bus converter for one device
----------------	---



MFD ...

ELECTRICAL NETWORK ANALYSER

4 module DIN enclosure.

MFD 438	Multifunctional network analyser. Power supply 80...265V AC 100...300V DC. Communication protocol Bacnet MS/TP
MFD 448	Single-phase / three-phase multifunctional network analyser. Possibility of direct TA connection with secondary 1-5A Power supply 80...265V AC 100...300V DC Modbus RS 485 communication protocol
MFD 548	Single-phase / three-phase multifunctional network analyser. Possibility of direct TA connection with secondary 1-5A Power supply 80...265V AC 100...300V DC Modbus RS 485 communication protocol MID-certified version
MFD 418	Three-phase electrical network analyser with Rogowsky coils

PRODUCTS RELATED TO MFD 418

BRK 001	Rogowsky 1660A coils (32.5A - 1950A)
BRK 003	Extension for Rogowsky 3-meter Coils

OPENABLE OR PASS-THROUGH CURRENT TRANSFORMERS AVAILABLE ON REQUEST



MHN ...

COMPACT MECHANICAL THERMAL ENERGY METERS (3...90 °C)

Suitable for measuring thermal energy in heating and air conditioning systems. They can be installed indifferently on the supply or on the return.

Energy meters with:

- hot/cold

CERTIFICATION: MID DE-07-MI004-PTB 025

ACCURACY CLASS: EN 1434-1:2007, class 3

	DN inches	Connections inches	Tmax. °C	Qp m ³ /h	Qs m ³ /h	Qstart lt/h	Qi lt/h horizz. Vert.	Kws m ³ /h	Δp Qp kPa
MHN 15-1,5	1/2"	3/4"	90	1.5	3	7	7 7	3.5	19.6
MHN 20-2,5	3/4"	1"		2.5	5	10	10 10	6.3	16.5



PROTOCOLS FOR COMMUNICATION

M-Bus

MHF ...

COMPACT MECHANICAL THERMAL ENERGY METERS (3...90 °C)

Suitable for measuring thermal energy in heating and air conditioning systems. They can be installed indifferently on the supply or on the return. Energy meters with:

- Data transmission via M-Bus cable

-hot/cold

CERTIFICATION: MID DE-07-MI004-PTB 025; ACCURACY CLASS : EN 1434-1:2007, class 3

The unit is equipped with M-Bus, which can be converted to C-Bus with CMC 328, CMC 422 e CMC 428 converters.

	DN inches	Connections inches	Tmax. °C	Qp m ³ /h	Qs m ³ /h	Qstart lt/h	Qi lt/h horizz. Vert.	Kws m ³ /h	Δp Qp kPa
MHF 15-1,5	1/2"	3/4"	90	1.5	3	7	7 7	3.5	19.6
MHF 20-2,5	3/4"	1"		2.5	5	10	10 10	6.3	16.5

RELATED PRODUCTS

3 IMP	Addition of 3 pulse inputs
--------------	----------------------------

KEY

(1): Flange to flange length

2): Certification MI-001.

Qp: Nominal flow rate:
Maximum continuous flow rate measurable by meter

Qs: Maximum flow rate temporary bearable by the meter

Qt: Transition flow rate: minimum limit with error less than ±2%

Qi: Minimum limit flow rate: minimum limit with error less than ±5%

Kws: Flow rate coefficient: Flow rate m³/h pressure drop

Δp Qp: Pressure drop at nominal flow rate Qp



PROTOCOLS FOR COMMUNICATION

WIRELESS **M-Bus**

MHR ...

WIRELESS THERMAL ENERGY METERS

This is a tool for metering the thermal energy supplied to utilities using water as the energy transport element. It can be used in a wide range of systems: heating, air conditioning and typical domestic systems. Can be installed on the supply or return, after appropriate configuration by means of an infrared optical head.

MID MI004 CERTIFICATION

Energy meters with:

- Data transmission via wireless M-Bus
- Hot/cold

	DN inches	Connections inches	Tmax. °C	Qp m³/h	Qs m³/h	Qi lt/h horizz. Vert.	Kws m³/h	Δp Qp kPa
MHR 15-1,5	1/2"	3/4"	90	1.5	3	7 7	3.5	19.6
MHR 20-2,5	3/4"	1"		2.5	5	10 10	6.3	16.5

RELATED PRODUCT

3 IMP	Addition of 3 pulse inputs
-------	----------------------------



PROTOCOLS FOR COMMUNICATION

M-Bus

UHF ...

COMPACT ULTRASONIC THERMAL ENERGY METERS M-BUS (3...90 °C)

Suitable for measuring thermal energy in heating and air conditioning systems. They can be installed indifferently on the supply or on the return. Energy meters with: Hot/cold; Data transmission via M-Bus via cable.

CERTIFICATION: MID DE-07-MI004-PTB 025;

ACCURACY CLASS : EN 1434-1:2007, class 3.

The unit is equipped with M-Bus, which can be converted to C-Bus with CMC 328 converter.

	DN mm	Connection inches	T max °C	Qp m³/h	Qs m³/h	Qi lt/h	Δp Qp kPa
UHF 15-1,5	15	G3/4"	90	1,5	3	12	21.0
UHF 20-2,5	20	G1"		2,5	5	25	12.0
UHF 20-3,5		G1"		3,5	7	28	21.0
UHF 25-3,5	25	G1" 1/4					
UHF 25-6		G1" 1/4					
UHF 40-10	40	G2"		10	20	100	11.0

RELATED PRODUCTS

3 IMP	Addition of 3 pulse inputs
-------	----------------------------



UHN ...

COMPACT ULTRASONIC THERMAL ENERGY METERS (3...90 °C)

Suitable for measuring thermal energy in heating and air conditioning systems.

They can be installed indifferently on the supply or on the return.

Energy meters with:

- hot/cold

CERTIFICATION : MID DE-07-MI004-PTB 025;

ACCURACY CLASS : EN 1434-1:2007, class 3

	DN mm	Connections inches	T max °C	Qp m³/h	Qs m³/h	Qi lt/h	Δp Qp kPa
UHN 15-1,5	15	G3/4"	90	1.5	3	12	21.0
UHN 20-2,5	20	G1"		2.5	5	25	12.0
UHN 20-3,5		G1"		3.5	7	28	21.0
UHN 25-3,5	25	G1" 1/4					
UHN 25-6		G1" 1/4					
UHN 40-10	40	G2"		10	20	100	11.0



PROTOCOLS FOR COMMUNICATION

Modbus

UHM ...

MISURATORI DI ENERGIA TERMICA COMPATTI ULTRASONICI MODBUS (3...90 °C)

Suitable for measuring thermal energy in heating and air conditioning systems. Can be installed indifferently on the supply or on the return, after appropriate configuration by means of an infrared optical head.

Energy meters with Modbus protocol communication via cable. ACCURACY CLASS: EN 1434-1:2007, Class 3..

CERTIFICATION: MID DE-074-MI0054-PTB 025

	DN mm	Connections inches	T max °C	Qp m³/h	Qs m³/h	Qi lt/h	Δp Qp kPa
UHM 15-1,5	15	G3/4"	90	1,5	3	12	21.0
UHM 20-2,5	20	G1"		2,5	5	25	12.0
UHM 20-3,5		G1"		3,5	7	28	21.0
UHM 25-3,5	25	G1" 1/4					
UHM 25-6		G1" 1/4					
UHM 40-10	40	G2"		10	20	100	11.0

KEY	Qs: Maximum flow rate temporary bearable by the meter	Qi: Minimum limit flow rate: minimum limit with error less than ±5%	Δp Qp: Pressure drop at nominal flow rate Qp
Qp: Nominal flow rate: Maximum continuous flow rate measurable by meter	Qt: Transition flow rate: minimum limit with error less than ±2%	Kws: Flow rate coefficient: Flow rate m³/h pressure drop	



PROTOCOLS FOR COMMUNICATION

WIRELESS **M-Bus**

UHR ...

COMPACT ULTRASONIC THERMAL ENERGY METERS WIRELESS (3...90 °C)

Suitable for measuring thermal energy in heating and air conditioning systems. Can be installed indifferently on the supply or on the return, after the appropriate configuration by means of an infrared optical head. Energy meters with: Hot/cold; Data transmission via wireless M-Bus

CERTIFICATION: MID DE-07-MI004-PTB 025; ACCURACY CLASS : EN 1434-1:2007, class 3

	DN mm	Connections inches	T max °C	Qp m³/h	Qs m³/h	Qi l/h	Δp Qp kPa
UHR 15-1,5	15	G3/4"	90	1,5	3	12	21.0
UHR 20-2,5	20	G1"		2,5	5	25	12.0
UHR 20-3,5		G1"		3,5	7	28	21.0
UHR 25-3,5	25	G1" 1/4		6	12	60	20.0
UHR 25-6		G1" 1/4		10	20	100	11.0
UHR 40-10	40	G2"					

RELATED PRODUCTS

3 IMP	Addition of 3 pulse inputs
-------	----------------------------



KEY

- Q1:** The minimum flow rate at which the counter must operate while respecting the defined errors
- Q2:** The minimum flow rate at which the counter must operate while respecting the defined errors with respect to the upper flow rate range
- Q3:** Permanent flow rate: continuous flow rate measurable by the counter
- Q4:** Overload flow rate: maximum supported by the counter Δp
- Q3:** Permanent flow rate pressure drop
- Kvs:** Flow rate coefficient: Flow rate in m³/h at 1 bar pressure drop

(*) Depending on installation location (further information on data sheet) at costergroup.eu

KUF-KUC

SINGLE-JET TURBINE VOLUMETRIC METERS WITH "REED" CONTACT PULSE EMITTER FOR DOMESTIC HOT AND COLD SANITARY WATER

Turbine volumetric meters for metering domestic hot and cold water. Output with "reed" contact pulse emitter. KUF/KUC 15 -20 Compliance: (B) TCM 142/20 -5700 (D) 0119-SJ-A010-08 KUF 25 Compliance: (B) TCM142/08 - 4627 (D) 0119-SJ-A010-08 MID MI001 CERTIFICATION

DO NOT USE THESE METERS FOR COLD OR HOT WATER CIRCULATION IN HEATING/AIR CONDITIONING SYSTEMS. THE WATER IN THESE SYSTEMS CONTAINS MANY IMPURITIES THAT DO NOT ALLOW CORRECT METERING.

	DN inches	length mm	R Q1/Q3	Q3 m³/h	Q4 m³/h	Q2 l/h	Q1 l/h	Δp Q3 bar	Kws m³/h	Pulse emitters l/pul
Tmax 50 °C										
KUF 15D	1/2"	110	100	2.5(*)	3.13(*)	40(*)	25(*)	0.63	3	10
KUF 20D	3/4"	130		4(*)	5(*)	64(*)	40(*)		5	
KUF 25C	1"	160		6.3	7.88(*)	63.01(*)	39.38(*)		8	
Tmax 90 °C										
KUC 15D	1/2"	110	100	2.5(*)	3.13(*)	40(*)	25(*)	0.63	3	10
KUC 20D	3/4"	130		4(*)	5(*)	64(*)	40(*)		5	



PROTOCOLS FOR COMMUNICATION

WIRELESS **M-Bus**

KUF ..W-N - KUC ..W-N

WIRELESS METERS

Single-jet dry dial meter with superdry magnetic transmission for cold or hot water.

KUF/KUC 15 -20 Compliance: (B) TCM 142/20 -5700 (D) 0119-SJ-A010-08

MID MI-001 CERTIFICATION

	DN inches	length mm	R Q1/Q3	Q3 m³/h	Q4 m³/h	Q2 lt/h	Q1 lt/h	Δp Q3 kPa	Kws m³/h
Tmax 50 °C									
KUF 15W-N	1/2"	110	100	2.5(*)	3.13(*)	40(*)	25(*)	0.63	3
KUF 20W-N	3/4"	130		4(*)	5(*)	64(*)	40(*)		5
Tmax 90 °C									
KUC 15W-N	1/2"	110	100	2.5(*)	3.13(*)	40(*)	25(*)	0.63	3
KUC 20W-N	3/4"	130		4(*)	5(*)	64(*)	40(*)		5



PROTOCOLS FOR COMMUNICATION

M-Bus

IEF 276

ELECTRONIC HOT/COLD ENERGY INTEGRATOR

Metering of heating and cooling energy. CERTIFICATION: MID MI 004 With additional inputs

ESSENTIAL SENSORS AND ACCESSORIES: 1 pair of sensors + 1 immersion kit, or

1 pair of sensors + 1 pair of pockets, or

1 pair of sensors + 1 direct immersion kit + 1 pair of "T" fittings Sensors and accessories comply with MID Directive 2004/22/EC.

IEF 276-10	Electronic energy integrator litres/pulse 10 ⁽¹⁾
IEF 276-100	Electronic energy integrator litres/pulse 100 ⁽¹⁾
IEF 276-1000	Electronic energy integrator litres/pulse 1000 ⁽¹⁾

RELATED PRODUCTS

SPT 106	Pair of sensors with 10 metre cable diameter 6 mm
SPT 006	Pair of sensors with 3-metre cable 6 mm diameter Pair of brass pockets for sensors (1/4")
GIS 062	Pair of brass pockets for sensors (1/4") (1/4") 62 + 18 mm
GIS 112	Pair of brass pockets for sensors (1/4") 112 + 18 mm
3 IMP	Addition of 3 pulse inputs

(1) Different pulse weights on request



PROTOCOLS FOR COMMUNICATION



IEM 277

ELECTRONIC MODBUS/RTU HOT/COLD ENERGY INTEGRATOR

Metering of heating and cooling energy. The device requires an additional 12 V DC power supply. CERTIFICATION: MID MI 004

ESSENTIAL SENSORS AND ACCESSORIES:

1 pair of sensors + 1 immersion kit, or 1 pair of sensors + 1 pair of pockets, or 1 pair of sensors + 1 direct immersion kit + 1 pair of "T" fittings Sensors and accessories comply with MID Directive 2004/22/EC

IEM 277-10	Modbus/RTU electronic energy integrator litres/pulse 10 ⁽¹⁾
IEM 277-100	Modbus/RTU electronic energy integrator litres/pulse 100 ⁽¹⁾
IEM 277-1000	Modbus/RTU electronic energy integrator litres/pulse 1000 ⁽¹⁾

RELATED PRODUCTS

SPT 106	Pair of sensors with 10 metre cable diameter 6 mm
SPT 006	Pair of sensors with 3 metre cable diameter 6 mm
GIS 062	Pair of brass pockets for sensors (1/4") 62 + 18 mm
GIS 112	Pair of brass pockets for sensors (1/4") 112 + 18 mm



PROTOCOLS FOR COMMUNICATION

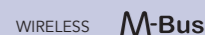

IEW 278

WIRELESS HOT/COLD ELECTRONIC ENERGY INTEGRATOR

Metering of heating and cooling energy. CERTIFICATION: MID MI 004 With additional inputs

ESSENTIAL SENSORS AND ACCESSORIES:

1 pair of sensors + 1 immersion kit, or 1 pair of sensors + 1 pair of pockets, or 1 pair of sensors + 1 direct immersion kit + 1 pair of "T" fittings Sensors and accessories comply with MID Directive 2004/22/EC.

IEW 278-10	Wireless M-Bus electronic energy integrator litres/pulse 10 ⁽¹⁾
IEW 278-100	Wireless M-Bus electronic energy integrator litres/pulse 100 ⁽¹⁾
IEW 278-1000	Wireless M-Bus electronic energy integrator litres/pulse 1000 ⁽¹⁾

RELATED PRODUCTS

SPT 106	Pair of sensors with 10 metre cable diameter 6 mm
SPT 006	Pair of sensors with 3 metre cable diameter 6 mm
GIS 062	Pair of brass pockets for sensors (1/4") 62 + 18 mm
GIS 112	Pair of brass pockets for sensors (1/4") 112 + 18 mm
3 IMP	Addition of 3 pulse inputs

⁽¹⁾ Different pulse weights on request



KMF ...

PROTECTED ROLLERS MULTI JET METERS FOR COLD WATER WITH "REED" CONTACT PULSE EMITTER

Multi-jet turbine volumetric meters for domestic cold water metering. Output with "reed" contact pulse emitter compatible with all meters with pulse input. KMF CERTIFICATION: MID MI-001

Tmax 50 °C horizontal	DN inches	lung. mm	Q3 m³/h	Q4 m³/h	Q1 lt/h	Q2 lt/h	Kws m³/h	Pulse emitters l/pul
KMF 15D ⁽³⁾	1/2"	165	2.5	3.13	15.63	25	3.0	10
KMF 20D ⁽³⁾	3/4"	190	4.0	5.0	25	40	5.0	
KMF 25C ⁽³⁾	1"	260	6.3	7.9	40	63	6.8	100
KMF 32C ⁽³⁾	1" 1/4		10	12.5	62.50	100	9.5	
KMF 40C ⁽³⁾	1" 1/2	300	16	20.0	100	160	20	
KMF 50C ⁽³⁾	2"		25	31.0	156	250	30	

⁽³⁾ Depending on installation location (further information on data sheet) at costergroup.eu

KEY

Q1: The minimum flow rate at which the meter must operate while respecting the defined errors

Q2: The minimum flow rate at which the meter must operate while respecting the defined errors with respect to the upper flow rate range

Q3: Permanent flow rate: continuous flow rate measurable by the meter
Q4: Overload flow rate: maximum supported by the counter

Kvs: Flow rate coefficient: Flow rate in m³/h at 1 bar pressure drop
Δp Q3: Pressure drop at permanent flow



KWP-KWM

WOLTMAN TURBINE VOLUMETRIC METERS WITH "REED" CONTACT PULSE EMITTER

Woltman turbine volumetric meters for measuring domestic water (KWP...) and water circulating in heating/cooling systems (KWM...). Output with "reed" contact pulse emitter compatible with all meters with pulse input and IEF and IEW integrators. KWP ... CERTIFICATION: MI-001 KWM CERTIFICATION ...: MI-004 Although KWM... meters are approved up to 130 °C, for application in heating systems, the use of static-type volumetric meters, such as the ultrasonic KMHG and KMHF models, is recommended. For length see data sheet at www.costergroup.eu

Cold water	DN mm	Tmax °C	Q3 m³/h	Q4 m³/h	Q2 m³/h		Pulse emitters l/pul
					vert.	horizz.	
KWP 50C	50	50	40	50	0.64	-	100
KWP 65C	65		63	78.8	1.01		
KWP 80C	80		100	125	1.6		
KWP 100C	100		160	200	2.56		
KWP 125M	125		250	312.5	4.0		1000
KWP 150M	150						
KWP 200M	200						

Hot water	DN mm	Tmax °C	Qp m³/h	Qs m³/h	Qi m³/h		Pulse emitters l/pul
					vert.	horizz.	
KWM 50/C1	50	130	15	30	1.5	0.6	100
KWM 65/C1	65		25	50	2.5	1	
KWM 80/C1	80		40	80	4	1.6	
KWM 100/C1	100		60	120	6	2.4	
KWM 125/C1	125		100	200	10	4	1000
KWM 150/C1	150						



KMHG - KBHF

ULTRASONIC VOLUMETRIC METERS (5...130 °C) WITH ELECTRONIC PULSE EMITTER FOR CIRCULATING WATER IN HEATING SYSTEMS V

Ultrasonic volumetric meters for measuring circulating water in heating and air conditioning systems, which can be installed on the return. Not compatible with glycol. Output with compatible electronic pulse emitter with thermal energy integrators IEF ... and IEW ... MID CERTIFICATION DE-07-MI004-OJC218 accuracy class EN 1434 class 2. These ultrasonic meters are intended for use with fluid temperatures ranging 10 to 130 °C for heating applications and 5 to 50 °C for air conditioning applications. For dimensions see data sheet at www.costergroup.eu

THREADED	DN mm	PN	Qp m³/h	Qs m³/h	Qi lt/h	Qstart lt/h	Kws	Δp Qp kPa	litres pulse
KMHG 25-3,5	25	16	3.5	7	35	14	15	5.5	10
KMHG 25-6			6	12	60	12	16	14	
KMHG 40-10	40		10	20	100	28	30	11	

FLANGED	DN mm	PN	Qp m³/h	Qs m³/h	Qi lt/h	Qstart lt/h	Kws	Δp Qp kPa	litres pulse
KBHF 50-15	50	25	15	30	150	10	2.30	4.3	10
KBHF 65-25	65		25	50	250	20	4.46	2.8	
KBHF 80-40	80		40	80	400	30	8.31	2.3	
KBHF 100-60	100		60	120	600	50	10.30	3.4	100
KBHF 125-100	125		100	200	1000	80	13.68	5.3	
KBHF 150-150	150		150	300	1500	100	18.90	6.3	
KBHF 200-250	200		250	500	2500	200	38.16	4.3	
KBHF 250-400	250	400	800	4000	300	57.56	4.8		
KBHF 300-600	300	600	1200	6000	400	78.52	5.8		

KEY Certification MI001
Q1: The minimum flow rate at which the counter must operate while respecting the defined errors
Q2: The minimum flow rate at which the counter must operate while respecting the defined errors with respect to the upper flow rate range
Q3: Permanent flow rate: continuous flow rate measurable by the meter
Q4: Overload flow rate: maximum supported by the counter
Kvs: Flow rate coefficient: Flow rate in m³/h at 1 bar pressure drop
Δp Q3: Pressure drop at permanent flow

KEY Certification MI004
Qp: Nominal flow rate: Maximum continuous flow rate measurable by the meter
Qs: Maximum temporary flow rate supported by the meter
Qt: Transition flow rate: minimum limit with error less than ±2%
Qi: Minimum limit flow rate: minimum limit with error less than ±5%
Kvs: Flow rate coefficient: Flow rate in m³/h at 1 bar pressure drop
Δp Qp: Pressure drop at nominal flow rate Qp

^(*) Depending on installation location (further information on data sheet) at costergroup.eu

KEY
Q1: The minimum flow rate at which the meter must operate while respecting the defined errors
Q2: The minimum flow rate at which the meter must operate while respecting the defined errors with respect to the upper flow rate range
Q3: Permanent flow rate: continuous flow rate measurable by the meter
Q4: Overload flow rate: maximum supported by the counter
Kvs: Flow rate coefficient: Flow rate in m³/h at 1 bar pressure drop
Δp Q3: Pressure drop at permanent flow



PROTOCOLS FOR COMMUNICATION

C←BUS

XGG 618

"DAY DEGREES" METERING AND STORAGE UNIT

Counts and records the trend of conventional winter day degrees.
 ESSENTIAL SENSORS: 1 outdoor sensor for metering day degrees; model SGG 001..

RELATED PRODUCTS

ACB 460 Plug-in for communication via C-Bus



PROTOCOLS FOR COMMUNICATION

M-Bus

EQX 424

DATA LOGGER WITH M-BUS PROTOCOL

M-Bus/ModBus protocol converter for thermal energy meter data acquisition.
 4 module DIN enclosure.
 24V AC/DC power supply.



PROTOCOLS FOR COMMUNICATION

C←BUS

UCI 328

METERING UNIT WITH TWO PULSE INPUTS (CONTACT CLOSURES)

Counts and records the trend of conventional winter day degrees.
 ESSENTIAL SENSORS: 1 outdoor sensor for metering day degrees; model SGG 001.



PROTOCOLS FOR COMMUNICATION

M-Bus

EQL ...

M-BUS LEVEL CONTROL

To manage 60 or 250 devices. Data reading from M-Bus cable type meters.
 4 module DIN enclosure.

EQL 060 M-Bus converter to manage up to 60 devices on the same M-Bus line.

EQL 250 M-Bus converter to manage up to 250 devices on the same M-Bus line.



PROTOCOLS FOR COMMUNICATION

M-Bus

RPT 001

WIRELESS M-BUS REPEATER/RECEIVER

For meters with wireless M-Bus protocol
 The repeater makes it possible to extend the network by increasing the wireless range, collecting the data of the relevant distribution units, and then transmitting them to the Concentrator.
 230V AC power supply.

"DISTRIBUTION BOXES" system

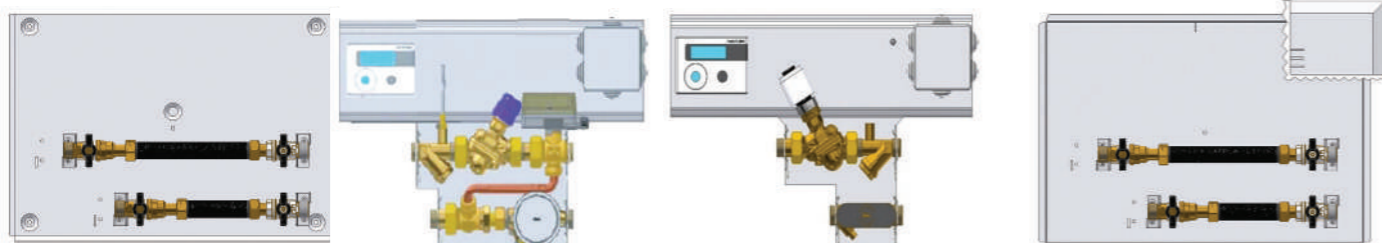

FOR MODEL SELECTION AND QUOTATIONS CONTACT YOUR LOCAL RETAILER

- BME 350** Pre-installation metal box for MME 350 module
- PME 350** Pre-installation metal plate for MME 350 module
- MME 350** Single zone distribution and metering module with 2- or 3-way zone valve.

Possibility of heating/cooling line:

- 1/2" routing; and 3/4" connection; (MME 350-5000)
- 3/4" routing; and 1" connection; male (MME 350 6000)

Consumption metering:

- No. 1 thermal and cooling energy meter

Power supply: 230 Volt~ (MME 500...); 24 Volt~ (MME 500.../24V)

Bus for centralised reading and C-Bus or M-Bus remote control

NOTE: Ensure a head of at least 2.5 metres of water column at the box inlet, generated by the primary circuit pump (boiler/cooler circuit).

NOTE: with a simple gesture, in all models, it is possible to change the side of the fluid inlet (from LH to RH and vice versa).

PROTOCOLS FOR COMMUNICATION

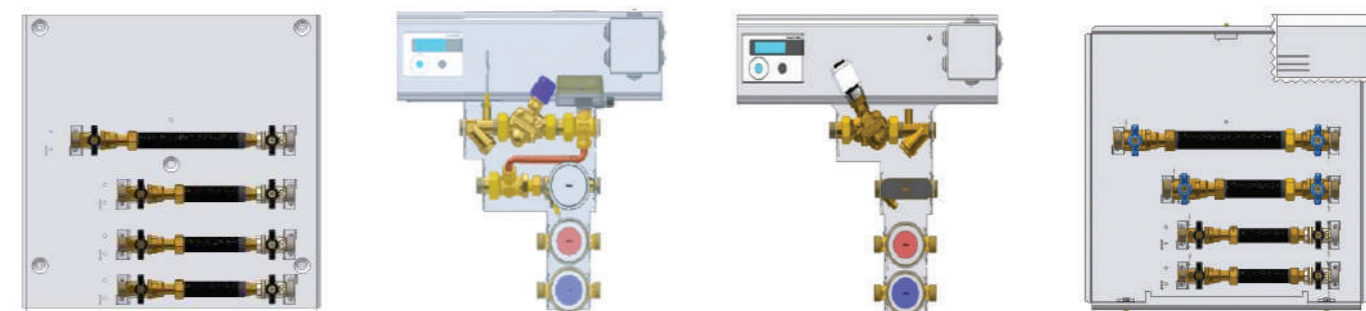

FOR MODEL SELECTION AND QUOTATIONS CONTACT YOUR LOCAL RETAILER

- BME 500** Pre-installation metal box for MME 500 module
- PME 500** Pre-installation metal plate for MME 500 module
- MME 500** Single zone distribution and metering module with 2-way or 3-way zone valve

Heating/cooling line possible:

- 1/2" routing; and 3/4" connection; (MME 500-5xx0)
- 3/4" routing; and 1" connection; male (MME 500 6xx0)

Possibility of domestic hot and/or cold water lines:

- Domestic hot and/or cold water lines 1/2" routing; and 3/4" connection; male, 2.5 m³/h volumetric counters (MME 500-x110)
- Domestic hot and/or cold water lines 3/4" routing; and 1" connection; male, 4 m³/h volumetric counters (MME 500-x220)

Consumption metering:

- No. 1 thermal and cooling energy meter
- No. 2 cm³ domestic water meter

Power supply: 230 Volt~ (MME 500...); 24 Volt~ (MME 500.../24V)

Bus for centralised reading and C-Bus or M-Bus remote control

NOTE: Ensure a head of at least 2.5 metres of water column at the box inlet, generated by the primary circuit pump (boiler/cooler circuit).

NOTE: With a simple gesture, in all models, it is possible to change the side of the fluid inlet (from LH to RH and vice versa).

PROTOCOLS FOR COMMUNICATION



M M E 3 5 0 - x 0 0 0 / x x x

PME wall mounting plate

MME module

BME flush mounting box

1 3-way module with 3/4" automatic balancing valve (0.9 m³)

2 3-way module with 1" automatic balancing valve (1.7 m³)

5 2-way module with 3/4" automatic balancing valve (0.9 m³)

6 2-way module with 1" automatic balancing valve (1.7 m³)

0 without water grey **S** left **D** right

0 without domestic cold water

0 without water domestic hot water

MU M-Bus ultrasonic room counter
W wireless M-Bus counter

R room thermostat radio status receiver

Example

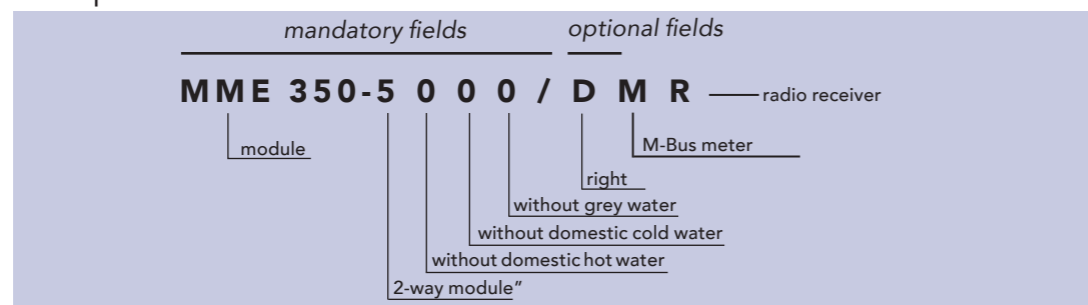

M M E 5 0 0 - x x x 0 / x x x

BME flush mounting box

MME module

PME wall mounting plate

1 3-way module with 3/4" (0.9 m³) automatic balancing valve

2 3-way module with 1" (1.7 m³) automatic balancing valve

5 2-way module with 3/4" (0.9 m³) automatic balancing valve

6 2-way module with 1" (1.7 m³) automatic balancing valve

S left **D** right

MU M-Bus ultrasonic room counter

W wireless M-Bus counter

0 without domestic cold water

1 with domestic hot water 2.5 m³ 3/4"

2 with domestic hot water 4 m³ 1"

R room thermostat radio status receiver

Example

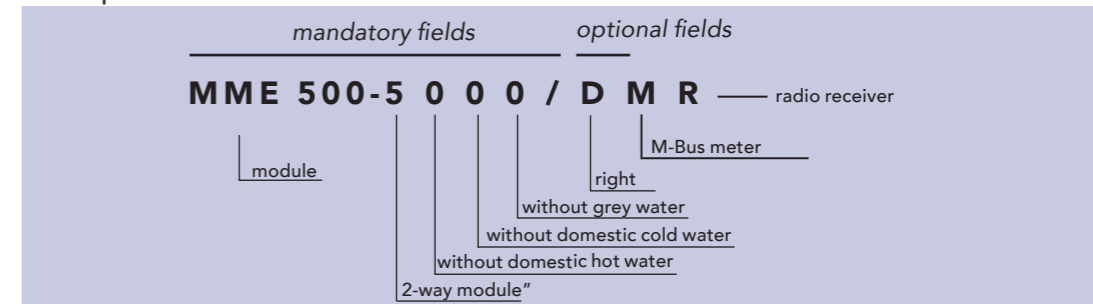

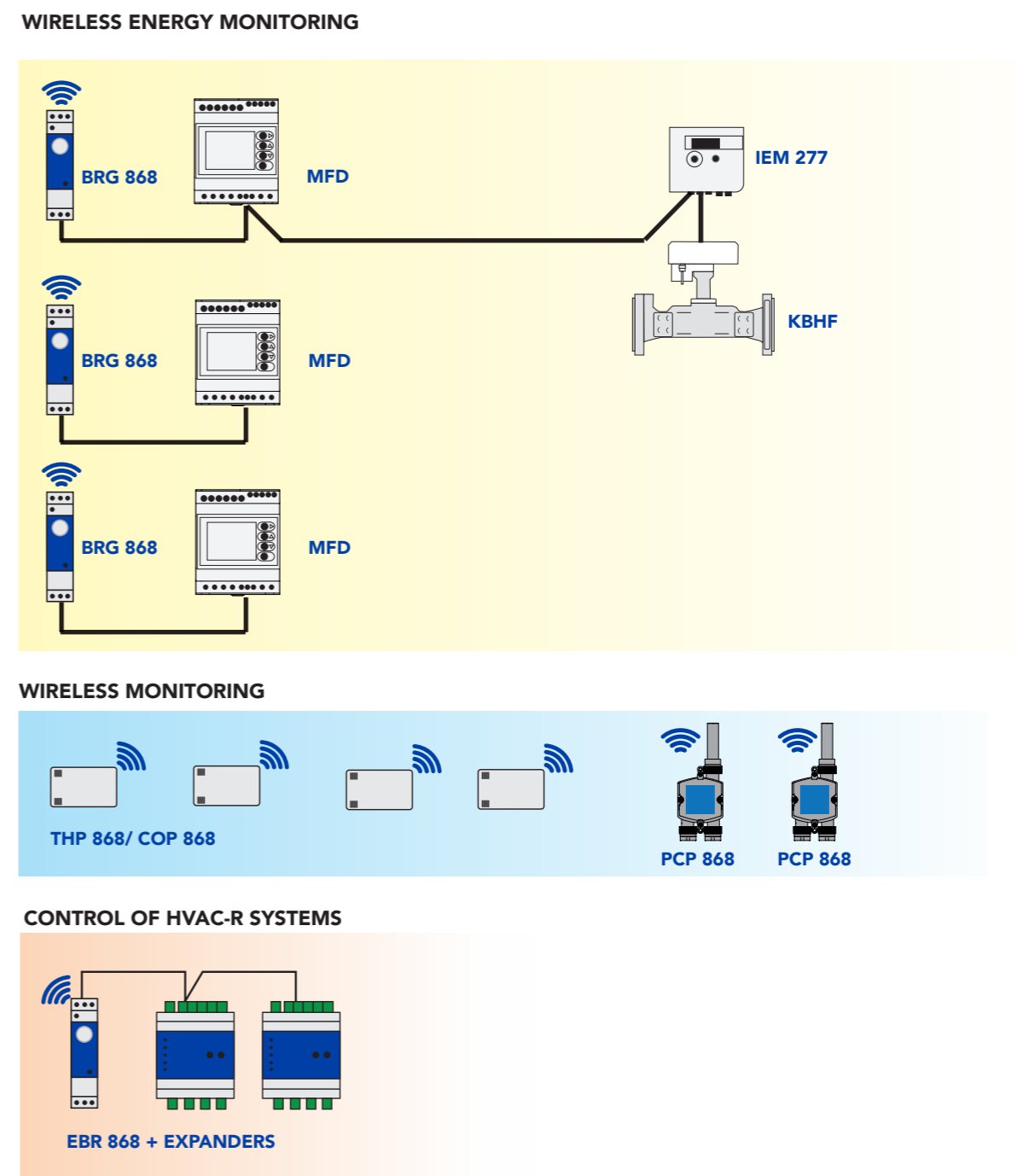
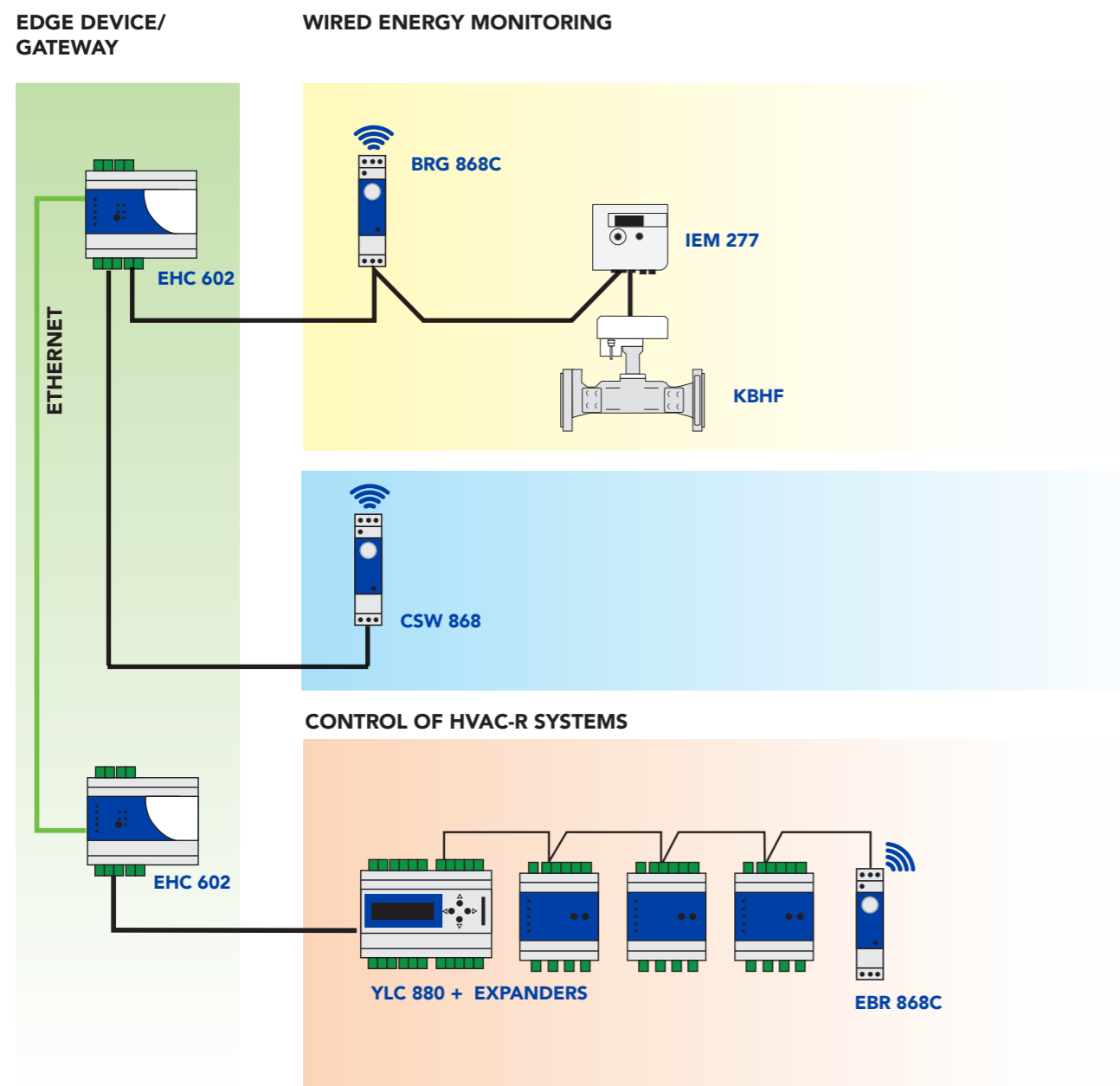

The Edge Device EHC ... overcomes the physical limitations of traditional cabling, offering a platform for full integration between monitoring variables and active control logic. Exploiting the robustness and range of Wireless technology on LoRa 868MHz protocol, the system allows it to reach every point in the building, guaranteeing installation flexibility and operational continuity.

The wireless ecosystem has three levels of application:

- **Capillary Environmental Monitoring:** The integration of the THP 868 (Temperature and Relative Humidity) and COP 868 (Temperature, RH and Air Quality/CO₂) sensors allows comfort parameters to be acquired directly from occupied zones, without any masonry work, providing the system with the necessary data for precise, on-demand regulation.
- **Metering and Advanced Energy Management:** With the CSW 868 concentrator, the metering infrastructure becomes totally wireless. It is possible to acquire consumption data via PCP 868 pulse modules (2 inputs) or, alternatively, to extend the data network to remote serial devices. Via the

BRG 868 bridge, the Modbus bus is 'transported' via radio, allowing the integration of electrical multimeters and thermal energy meters located in places difficult to access by cable.

- **Extension of Field Control (I/O):** LoRa technology is not limited to reading data but enhances the operational capabilities of the controller. Using the EBR 868 module, the local expander bus can be extended wirelessly. This makes it possible to bring the controller inputs and outputs to remote electrical panels or distant technical rooms, acting directly on the actuators and reading field states as if they were wired directly to the control unit.
- **Real-Time Energy Supervision:** The ecosystem is completed with the power of the WebGarage platform, natively integrated into the EHC hardware. This synergy transforms the acquired data into immediate decision-making tools: through dynamic energy dashboards updated in real time, it is possible to constantly monitor consumption flows, instantly identify any plant waste and intervene promptly to ensure maximum operational efficiency.





X SERIES

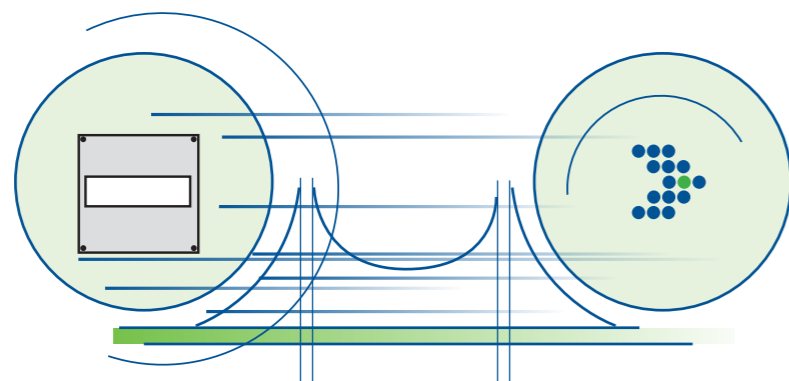

In a rapidly changing industry, true innovation lies not just in creating the new, but in knowing how to enhance what already exists. Coster renews its clear strategy: to safeguard the customer's investment, ensuring that the technology installed yesterday is ready for the challenges of tomorrow.

- **Extended Support for the X-Series.** Recognising the value and reliability of the historic X-Series, Coster does more than just ensure its continued production and technical support. We have taken a decisive step towards digitisation by developing specific proprietary drivers that allow these controllers to natively dialogue with state-of-the-art IT infrastructures.
- **The Bridge to WebGarage:** This strategic integration opens the door to WebGarage, our advanced supervision platform. Without the need to replace hardware in the field, X-Series managed systems are projected into a multi-access web environment, characterised by intuitive interfaces and, above all, complying with the strictest cybersecurity standards.

Through sustainable innovation, our vision allows for the harmonious co-existence of different technological generations. It is now possible to expand an existing system with the latest generation of devices, making them work in synergy with the X-Series on the same network.

This step-by-step approach to innovation minimises costs of revamping with no radical replacement but just targeted evolution and energy efficiency optimisation thanks to the innovation of new solutions applied to the robustness of the X Series .

With Coster, your system does not age: it evolves.



PROTOCOLS FOR COMMUNICATION

OPTIONAL
C←BUS C←RING

XCC 602

CONTROLLER FOR SEQUECE DI 2 BOILERS

Cascade command of 2 single-stage or two-stage boilers with or without shut-off valves.

ESSENTIAL SENSORS:

- 1 collector temperature sensor
- or
- 2 boiler sensors

OPTIONAL SENSOR: 1 outside sensor, 1 flue gas temperature sensor

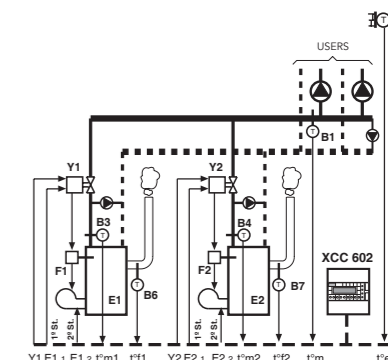

RELATED PRODUCTS

ACB 400	Plug-in for communication via C-Bus
ACD 655	Front panel mounting accessory



PROTOCOLS FOR COMMUNICATION

OPTIONAL
C←BUS C←RING

DTC 648

CLIMATE CONTROLLER FOR BOILERS IN SEQUENCE (UP TO 24 BOILERS)

ISC 648

RELAY COMMAND MODULE

Cascade command of multiple single-stage or two-stage boilers with or without shut-off valves composed of:

- 1 climate controller for boiler cascade command;
- 1...3 relay command modules for single/two stage burners and shut-off valves.

ESSENTIAL SENSOR: 1 collector or system flow sensor

OPTIONAL SENSORS: 1 outside sensor, 1 boiler sensor

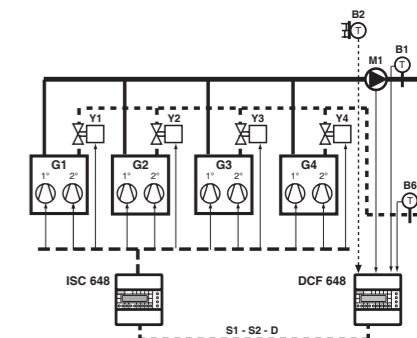

RELATED PRODUCTS

ASA 420	Accessory for connecting 4...20 mA DC active sensors. Converts the 4...20mA signal to an analogue signal
ACD 655	Front panel mounting accessory

DEVICES	Boilers with burners valves 1 stage	Boilers with burners valves 1 stage	Boilers with burners valves 2 stages	Boilers without burners valves 2 stages
1 DTC 648 + 1 ISC 648	up to 4	up to 8	up to 4	up to 4
1 DTC 648 + 2 ISC 648	up to 8	up to 16	up to 8	up to 8
1 DTC 648 + 3 ISC 648	up to 12	up to 24	up to 12	up to 12



DCF 648

CLIMATE CONTROLLER
REFRIGERATION OR HEAT PUMP
UNIT SEQUENCE



ISC 648

RELAY COMMAND MODULE

Cascade command of refrigeration units and heat pumps with or without shut-off valves consisting of:

- 1 climate controller for cascade command;
- 1...3 relay command modules for single/two stage units and shut-off valves.

ESSENTIAL SENSOR: 1 collector or system flow sensor

OPTIONAL SENSOR: 1 outside sensor; 1 generic sensor

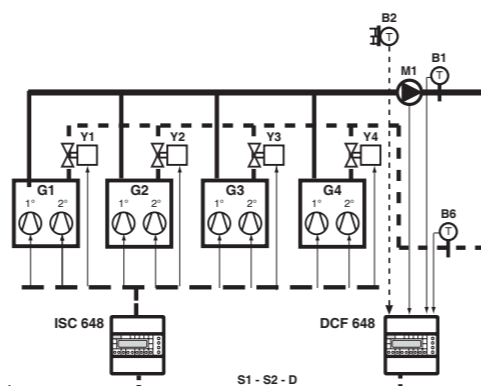

PROTOCOLS FOR COMMUNICATION

OPTIONAL
C←BUS **C←RING**

RELATED PRODUCTS

ASA 420 Accessory for connecting 4...20 mA DC active sensors. Converts the 4...20mA signal to an analogue signal

ACD 655 Front panel mounting accessory

DEVICES	Boilers with burner valves 1 stage	Boilers with burner valves 1 stage	Boilers with burner valves 2 stages	Boilers without burner valves 2 stages
1 DCF 648 + 1 ISC 648	up to 4	up to 8	up to 4	up to 4
1 DCF 648 + 2 ISC 648	up to 8	up to 16	up to 8	up to 8
1 DCF 648 + 3 ISC 648	up to 12	up to 24	up to 12	up to 12



XTC 638

OPTIMISING COMPENSATOR FOR
CENTRAL HEATING SYSTEM PLANT
BURNERS OF ANY KIND, COMPLETE
WITH SEQUENCE FOR SEVERAL BOILERS

Suitable for temperature control of any type of boiler. Controls the sequence of up to 7 boilers, all equipped with XCC 638 or XCC 618 controller.

ESSENTIAL AND OPTIONAL SENSORS:

See the data sheet, for the system type

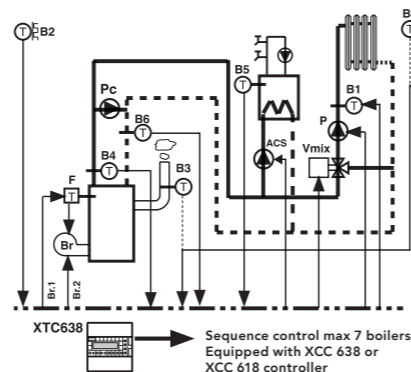

PROTOCOLS FOR COMMUNICATION

OPTIONAL
C←BUS **C←RING**

RELATED PRODUCTS

ACB 460 Plug-in for communication via C-Bus

ACD 655 Front panel mounting accessory



XCC 618

CONTROLLERS FOR BOILERS
1, 2 STAGES, MODULATING 3 POINTS
OR 0...10 V DC INPUT

Suitable for total boiler control for condensation and non-condensation boilers. Under the control of XTC 638, it can put the boiler in sequence with others (up to 7).

ESSENTIAL SENSOR: 1 boiler sensor

OPTIONAL SENSORS: 1 anticondensing sensor, 1 flue gas, 1 outside

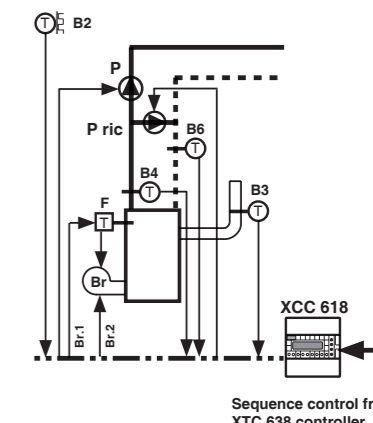

PROTOCOLS FOR COMMUNICATION

OPTIONAL
C←BUS **C←RING**

RELATED PRODUCTS

ACB 400 Plug-in for communication via C-Bus

ACD 655 Front panel mounting accessory



XCC 638

OPTIMISING COMPENSATOR FOR
BOILERS 1, 2 STAGE MODULATING
BURNERS 3 POINTS OR WITH 0...10 V DC
INPUT

Suitable for total boiler control for condensation and non-condensation boilers. Under the control of XTC 638, it can put the boiler in sequence with others (up to 7).

ESSENTIAL SENSOR: 1 boiler sensor

OPTIONAL SENSORS: 1 outside sensor, 1 room or flue gas, 1 boiler sensor

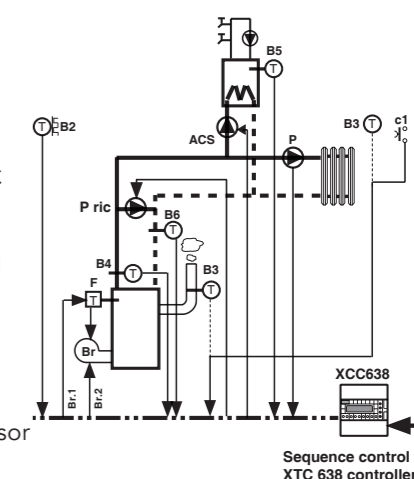

PROTOCOLS FOR COMMUNICATION

OPTIONAL
C←BUS **C←RING**

RELATED PRODUCTS

ACB 400 Plug-in for communication via C-Bus

ACD 655 Front panel mounting accessory



XTE 643

DIGITAL CLIMATE CONTROLLER
FOR CENTRAL HEATING PLANT

Suitable for the climate control of a central heating and domestic hot water control system.

ESSENTIAL SENSOR: 1 outside sensor, 1 system flow sensor

OPTIONAL SENSORS AND ACCESSORIES: 1 boiler sensor, 1 anticondensing sensor, 1 remote control

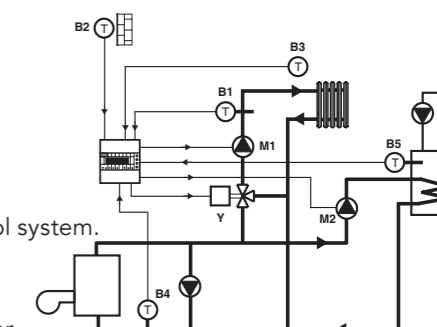

PROTOCOLS FOR COMMUNICATION

NO REMOTE MANAGEMENT
C←RING

RELATED PRODUCTS

ACD 655 Front panel mounting accessory



PROTOCOLS FOR COMMUNICATION

OPTIONAL C-BUS C-RING

XTE 600

OPTIMISING COMPENSATOR FOR CENTRAL HEATING SYSTEM

OPTIONAL REMOTE MANAGEMENT

Suitable for the climate optimisation of a central heating system and control of domestic hot water.

ESSENTIAL SENSORS: 1 outside sensor, 1 plant flow sensor
SENSORS AND ACCESSORIES: 1 room sensor, 1 flue gas sensor or 1 remote control, OPTIONAL: 1 sensor 4...20mA DC, 1 anti-condensation sensor

RELATED PRODUCTS

ACB 468	Plug-in for communication via C-Bus
ACD 655	Front panel mounting accessory

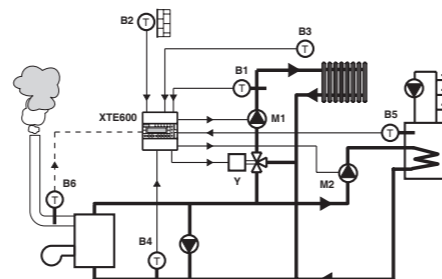

PROTOCOLS FOR COMMUNICATION

OPTIONAL C-BUS C-RING

XTE 602

OPTIMISER COMPENSATOR OF TEMPERATURE & FLOW

OPTIONAL REMOTE MONITORING

Suitable for climatic optimisation of two central heating circuits.

ESSENTIAL SENSORS : 1 outside sensor
2 plant flow sensor
SENSORS AND ACCESSORIES: 1 or 2 room sensors, 1 anticondensing sensor, 1 remote control

RELATED PRODUCTS

ACB 468	Plug-in for communication via C-Bus
ACD 655	Front panel mounting accessory

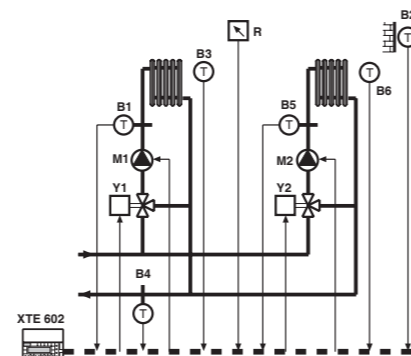

PROTOCOLS FOR COMMUNICATION

OPTIONAL C-BUS C-RING

XTE 611

OPTIMISER COMPENSATOR FOR HEATING PLANT ROOM

OPTIONAL REMOTE MONITORING

Suitable for climate optimisation of a heating system with:

- climate optimisation of a heating plant with:
- control of a central heating system
- control of domestic hot water
- control of two single-stage burners or one two-stage burner

ESSENTIAL SENSORS: 1 outside sensor, 1 boiler sensor, 1 plant flow sensor
OPTIONAL SENSORS AND ACCESSORIES: 1 room sensor, 1 boiler sensor 1 or 2 flue gas sensors, 1 remote control,

RELATED PRODUCTS

ACB 468	Plug-in for communication via C-Bus
ACD 655	Front panel mounting accessory

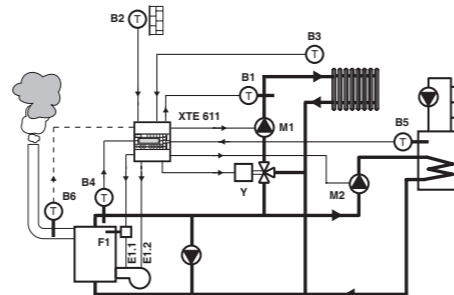

PROTOCOLS FOR COMMUNICATION

OPTIONAL C-BUS C-RING

XTP 600

OPTIMISER COMPENSATOR OF TEMPERATURE & FLOW

OPTIONAL REMOTE MONITORING

SUITABLE FOR CONDENSATION BOILERS

Suitable for the climate optimisation of a central heating system, optimising the flow rate through the control of a variable speed circulation pump. It optimises the efficiency of condensing boilers.

ESSENTIAL SENSORS: 1 outside sensor, 1 return site sensor,
SENSORS AND ACCESSORIES OPTIONAL: 1 heating flow sensor 1 room sensor, 1 boiler sensor 1 flue gas sensor, 1 remote control

RELATED PRODUCTS

ACB 468	Plug-in for communication via C-Bus
ACD 655	Front panel mounting accessory

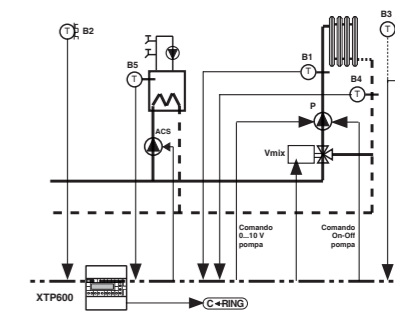

PROTOCOLS FOR COMMUNICATION

OPTIONAL C-BUS C-RING

XCS 633

COMPENSATING CONTROLLER WITH SEASON SWITCHING

OPTIONAL REMOTE MONITORING

Winter and summer climate control of fan coil or radiant panel plant flow temperature.

ESSENTIAL SENSORS: 1 outside sensor 1 plant flow sensor

OPTIONAL SENSORS AND ACCESSORIES: 1 room sensor, 1 temperature/humidity room sensor, 1 remote control,

RELATED PRODUCTS

ACB 468	Plug-in for communication via C-Bus
ACD 655	Front panel mounting accessory

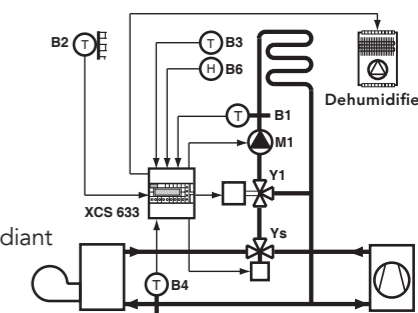



PROTOCOLS FOR COMMUNICATION

OPTIONAL C-BUS C-RING

XSS 633*

COMPENSATING CONTROLLER WITH SEASON SWITCHING
 OPTIONAL REMOTE MONITORING
 SLAVE UNIT FOR MULTICOSTER SYSTEM
 Winter and summer control of fan coil or radiant panel plant flow temperature.
 ESSENTIAL SENSORS: 1 outside sensor, 1 flow sensor

OPTIONAL SENSORS AND ACCESSORIES: 1 room sensor, 1 room temperature/humidity sensor, 1 remote control

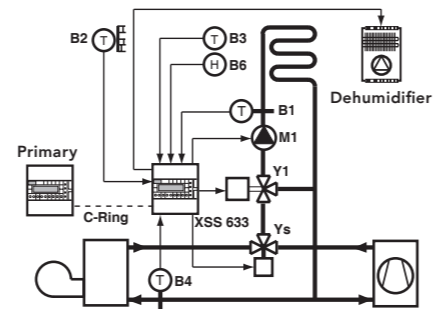

PROTOCOLS FOR COMMUNICATION

OPTIONAL C-BUS C-RING

XTT 618

CONTROLLER FOR DISTRICT HEATING SUBSTATION WITH A SINGLE EXCHANGER
 OPTIONAL REMOTE MONITORING

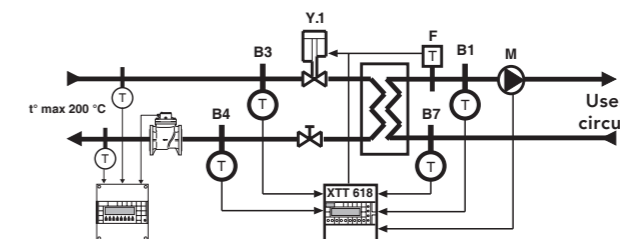

Regulation of district heating substations, consisting of an exchanger with a valve and a secondary circuit pump.

ESSENTIAL SENSORS: 1 secondary flow sensor
 SENSORS AND ACCESSORIES 1 outside sensor
 OPTIONAL: 1 primary flow sensor, 1 primary return sensor, 1 secondary return sensor

RELATED PRODUCTS

ACB 400	Plug-in for communication via C-Bus
ACD 655	Front panel mounting accessory



PROTOCOLS FOR COMMUNICATION

OPTIONAL C-BUS C-RING

XSE 600*

OPTIMISER COMPENSATOR "SLAVE" FOR HEATING PLANT ROOM
 OPTIONAL REMOTE MONITORING
 SLAVE UNIT FOR MULTICOSTER SYSTEM
 Suitable for climatic optimisation of a central heating system and to control domestic hot water.

ESSENTIAL SENSORS: 1 outside temperature sensor (as an alternative to outside temperature value on C-Ring), 1 flow sensor
 OPTIONAL SENSORS AND ACCESSORIES: 1 room sensor, 1 sensor 1 remote

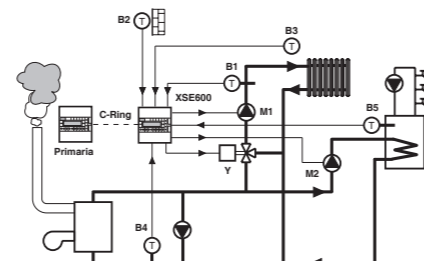

RELATED PRODUCTS

ACB 400	Plug-in for communication via C-Bus
ACD 655	Front panel mounting accessory



PROTOCOLS FOR COMMUNICATION

OPTIONAL C-BUS C-RING

XSE 602*

OPTIMISER COMPENSATOR SLAVE FOR TWO CIRCUITS
 OPTIONAL REMOTE MONITORING SYSTEM
 Suitable for climatic optimisation of two central heating circuits.

ESSENTIAL SENSORS: 1 outside sensor (as an alternative to the outside temperature value on C-Ring)
 OPTIONAL SENSORS AND ACCESSORIES: 1 or 2 room sensors, 1 anti-condensation sensor, 1 remote control

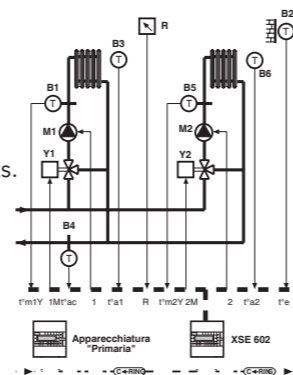

RELATED PRODUCTS

ACB 400	Plug-in for communication via C-Bus
ACD 655	Front panel mounting accessory



PROTOCOLS FOR COMMUNICATION

OPTIONAL C-BUS C-RING

XTT 608

CONTROLLER FOR DISTRICT HEATING SUBSTATION WITH TWO EXCHANGERS FOR THE SYSTEM AND HOT WATER
 OPTIONAL REMOTE MONITORING

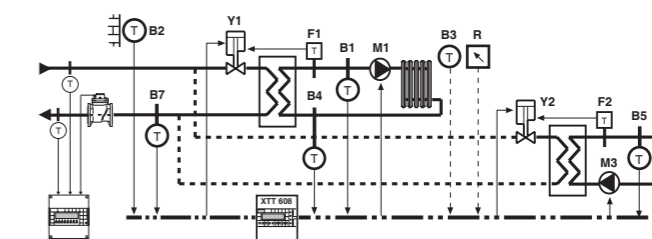

Regulation of district heating substations, consisting of two exchangers with valves and a secondary circuit pump.

ESSENTIAL SENSORS: 1 heating flow sensor, 1 DHW distribution sensor
 SENSORS AND ACCESSORIES: 1 outside sensor, 1 room sensor, 1 primary return sensor,
 OPTIONAL: 1 heating return sensor, 1 DHW distribution sensor, 1 remote control

RELATED PRODUCTS

ACB 460	Plug-in for communication via C-Bus
ACD 655	Front panel mounting accessory

(*) In order to function, this unit needs to be connected to at least one C-RING master unit



PROTOCOLS FOR COMMUNICATION

C-BUS

DAM 675

UNIT OF 5 CONTROLS, WITH COMPLETE TIME PROGRAMMING AND DISPLAY OF MEASUREMENTS, ALARMS AND STATUSES

5 On-Off controls with independent time programs and annual periods
7 measurement inputs or On-Off alarms
3 On-Off alarms

RELATED PRODUCTS

ASA 010	Accessory for connecting 0...10 V DC active sensors. It converts the 0...10 V signal of the sensors into an analogue signal
ASA 420	Accessory for connecting 4...20 mA active sensors
ACD 655	Front panel mounting accessory



PROTOCOLS FOR COMMUNICATION

OPTIONAL C-BUS C-RING

XPT 678

ROOM TEMPERATURE CONTROLLER AND OPTIMISER FOR 5 USER CIRCUITS USER AND BOILER

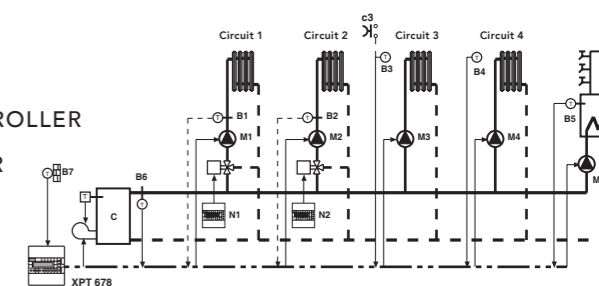

On-Off control for thermal system with time programming and/or room temperature control.
Boiler control according to system request.

RELATED PRODUCTS

ACB 460	Plug-in for communication via C-Bus
ACD 655	Front panel mounting accessory



PROTOCOLS FOR COMMUNICATION

OPTIONAL C-BUS

PLE 608

UNIT FOR CONTROLS WITH PROGRAMMABLE LOGIC FUNCTIONS

6 On-Off controls with time schedule and logic functions (PLC).

RELATED PRODUCT

ACD 655	Front panel mounting accessory
----------------	--------------------------------



PROTOCOLS FOR COMMUNICATION

OPTIONAL C-BUS

IPG 318

TWIN PUMP STEP CONTROLLER

Adapts the pump control On-Off signal of a controller to the control of twin pumps.



PROTOCOLS FOR COMMUNICATION

OPTIONAL C-BUS RS 232

XCO 428

TIME PROGRAMMER WITH TWO OUTPUTS AND TWO ALARMS

PRESET FOR SMS

XCO 428 is a universal time programmer with 2 outputs, complete with alarms, already preset to be controlled via SMS.

A kit with a GSM modem is also provided, to obtain a complete mini remote control.

RELATED PRODUCT

ACB 400	Plug-in for communication via C-Bus
----------------	-------------------------------------



PROTOCOLS FOR COMMUNICATION

OPTIONAL C-BUS

XPG 658

SEQUENCE CONTROLLER OF 5 PUMP OR OF 5 ELECTRICAL LOADS

It controls up to 5 pumps in sequence according to an On-Off control signal, or a 0...10 V DC signal.

It can also be used as a sequence controller of 5 electrical loads..

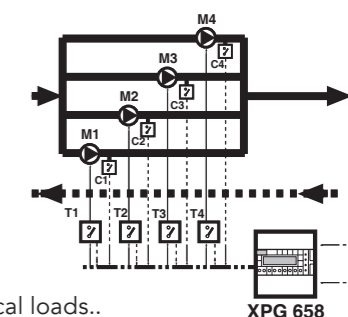

RELATED PRODUCTS

ACB 460	Plug-in for communication via C-Bus
ACD 655	Front panel mounting accessory



IPS 328

DOUBLE UNIVERSAL

RELAY CONTROL CONVERTER

Transforms any 2 On-Off controls into 2 relay controls.

It controls the recirculation pump for condensing boilers to optimise efficiency.

It controls the circulation pump with variable speed in systems with boxes.

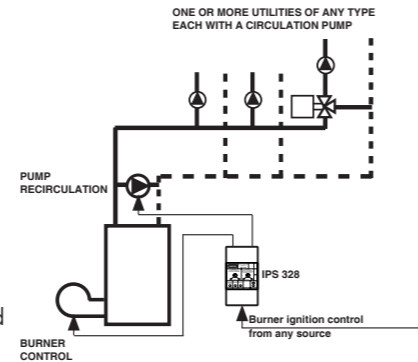

LCR 348

CONVERTER FOR C-RING: CONVERSION OF C-RING DATA TO RELAYS AND 0...10 V DC

Reader and converter of signals in the C-Ring

- reads the maximum temperature requested by the equipment connected in C-Ring
- converts this temperature into a 0...10 V DC signal to be sent to boilers with this input
- relay output when this temperature exceeds a certain value
- relay output for C-ring failure alarm

PROTOCOLS FOR COMMUNICATION

C-RING



CSA 344

TRIPLE SIGNAL SELECTOR

0...10 V DC

Selects the minimum, arithmetic mean and maximum value between 2...6 signals 0...10 V DC.



CSV 328

CONVERTER FROM 0...10 V DC, 4...20mA

OR TEMPERATURE SIGNALS TO 2 MODULATING RELAY CONTROLS
2 STAGES ON-OFF, MINIMUM AND MAXIMUM LIMITS

Converts a 0...10 Volt DC, or 4...20 mA signal into 2 relays controls to have:

- 3-point modulating control, to convert a 3-point actuator into a 0...10 V DC input
- 2-stage On-Off control to control e.g. 2 boilers in sequence
- 2 minimum and maximum limits On-Off controls

PROTOCOLS FOR COMMUNICATION

C-BUS



DRP 414

CONTROLLER FOR CIRCULATION PUMPS

WITH VARIABLE SPEED OR FIXED SPEED

Controls the flow rate of the circulation pump in a system to optimise efficiency of the condensing boilers.

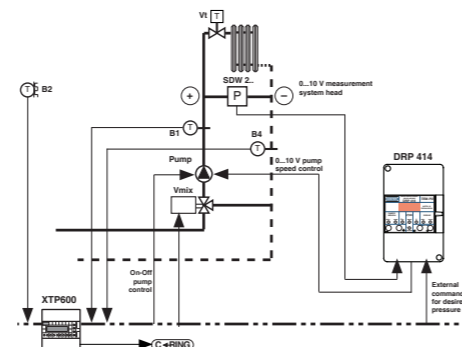

- one or two variable speed pumps
 - one fixed-speed pump plus one variable-speed pump
 - two fixed speed pumps
- 24 V AC controller power supply, such as pump head sensors to be used.



CSC 328

CONVERTER FROM 3 POINTS 0...10 V DC,
OR 4...20 mA TO TWO FREELY CONFIGURABLE

0...10 V DC SIGNALS

Converts a 3-point signal (e.g.: the 2 open and close relays of a controller), a 0...10 Volt or 4...20 mA output, into 2 0...10 Volt outputs, which can be freely programmed to control the sequence of 2 units (e.g.: boilers) which have 0...10 V DC as input.

PROTOCOLS FOR COMMUNICATION

C-BUS



OCR 348

INSERTS VARIOUS COMMANDS

INTO THE C-RING BUS

Inserts some external inputs into the C-Ring line to be able to control the temperature of a boiler or similar.

- 1 temperature measured by a standard sensor
- 1 input 0...10 V DC adjustable
- 1 general use switch

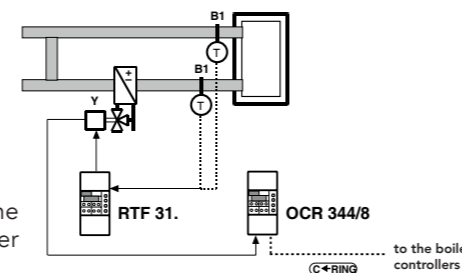

PROTOCOLS FOR COMMUNICATION

C-RING



CAP 328

CONVERTER AND AMPLIFIER
OF ACTIVE AND PASSIVE TEMPERATURE SENSORS

Converts the temperature measurement of a standard NTC passive sensor, or a 0...10 Volt DC or 4...20mA active temperature sensor into 2 outputs compatible with the temperature sensor inputs of the various COSTER GROUP devices. It amplifies the 2 compatible outputs to be able to power up to a maximum of 35 devices, all with the same input characteristics.

TYPE OF TEMPERATURE SENSOR

NTC 1	Outside Kohm (-30...40 °C)
NTC 10	Room Kohm (0...40 °C)
NTC 10	Kohm flow air (0...60 °C)
NTC 10	Kohm water (0...100 °C)

GROUPS OF EQUIPMENT WITH IDENTICAL MEASUREMENT CHARACTERISTICS

check the
CAP 328
data sheet



RTP 318

ON-OFF OR DIFFERENTIAL

TEMPERATURE CONTROLLER

Suitable for temperature control at a fixed point or to control the difference between 2 temperatures: Output = 1-stage On-Off control
ESSENTIAL SENSORS: 1 sensor for fixed point or 2 sensors per temperature difference.



DDM 328

DIFFERENTIAL CONTROLLER
OF 2 TEMPERATURES
OR 2 SIGNALS 0...10 V DC

Control with 2 relay output and 0...10 V DC, of the difference of two temperatures or 2 values 0...10 V DC, with the following function:

- modulating
- 2-stage
- minimum and maximum limit

PROTOCOLS FOR COMMUNICATION

C←BUS



PROTOCOLS FOR COMMUNICATION

C←BUS

DTF 31.

TEMPERATURE CONTROLLER

FOR VARIOUS USES

WITH C-BUS REMOTE MONITORING

It can be used for any temperature control needs, with following outputs:

- 3-point modulating with 2 relays
- On-Off with 1 or 2 stages
- On-Off proportional with 1-stage

ESSENTIAL SENSORS: 1 temperature sensor

OPTIONAL SENSORS

AND ACCESSORIES: 1 limit temperature sensor,
1 Temperature set point adjuster

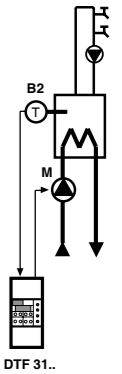

DTF 314 Controller with C-Bus remote control, 24 V AC power supply

DTF 318 Controller with C-Bus remote control, 230 V AC power supply



RTF 31.

TEMPERATURE CONTROLLER FOR VARIOUS USES

WITHOUT C-BUS REMOTE MONITORING

It can be used for any temperature adjustment requirement with following outputs:

- 3-point modulating with 2 relays
- On-Off with 1 or 2 stages
- On-Off proportional with 1-stage

ESSENTIAL SENSORS: 1 temperature sensor

OPTIONAL SENSORS

AND ACCESSORIES: 1 limit temperature sensor, 1 temperature set point adjuster

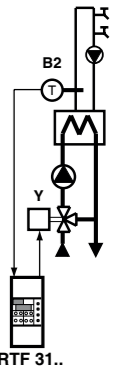

RTF 314 Controller with C-Bus remote control, 24 V AC power supply

RTF 318 Controller with C-Bus remote control, 230 V AC power supply



PROTOCOLS FOR COMMUNICATION

OPTIONAL
C←BUS C←RING

XTR 628

TEMPERATURE CONTROLLER

WITH TIME SCHEDULE

There are 3 controllers in the same unit with these functions:

- 1 modulating 3-point or 1- or 2-stage On-Off temperature controller with own time schedule
- 2 On-Off temperature controllers with own time schedules

ESSENTIAL SENSORS: 1, 2 or 3 temperature sensors

OPTIONAL SENSORS AND ACCESSORIES: 1 flow temperature sensor, 1 temperature set point adjuster

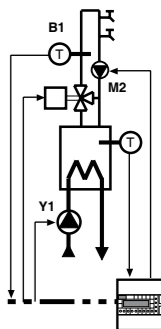

RELATED PRODUCTS

ACB 460 Plug-in for communication via C-Bus

ACD 655 Front panel mounting accessory



PROTOCOLS FOR COMMUNICATION

C-BUS

DRU 61.

UNIVERSAL CONTROLLER WITH RELAY

OUTPUT

It controls temperature or other physical variables such as pressure, level, etc.

- passive temperature sensor input or 0...10 V DC or 4...20 mA, from other active sensors.
- outputs: 3-point modulating control or 2...4 step sequencing.

ESSENTIAL SENSORS: 1 passive or active sensor

OPTIONAL SENSORS AND ACCESSORIES: 1 temperature set point adjuster

DRU 614	Universal controller, 24 V AC power supply
DRU 618	Universal controller, 230 V AC power supply

RELATED PRODUCT

ACD 655	Front panel mounting accessory
---------	--------------------------------

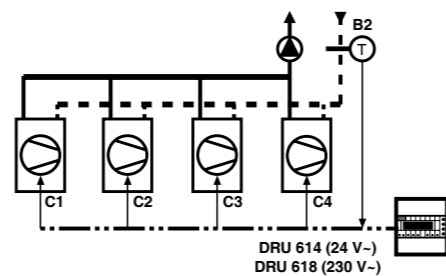

PROTOCOLS FOR COMMUNICATION

OPTIONAL

C-BUS

XTU 618

TEMPERATURE AND HUMIDITY CONTROLLER FOR FAN COILS

OPTIONAL REMOTE MONITORING

Suitable for winter and summer control of room temperature and humidity and/or delivery air in thermoventilation (fan coils) systems consisting of:

- 1 heating/cooling battery
- 1 humidifier

ESSENTIAL SENSOR: 1 room or Air duct temperature sensor

OPTIONAL SENSORS AND ACCESSORIES:

- 1 flow temperature sensor
- 1 outside sensor
- 1 room/Air duct relative humidity sensor
- 1 battery frost protection sensor
- 1 temperature Set point adjuster
- 1 remote control

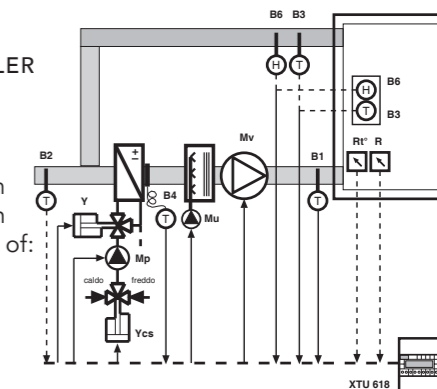

RELATED PRODUCTS

ACB 460	Plug-in for communication via C-Bus
ACD 655	Front panel mounting accessory



PROTOCOLS FOR COMMUNICATION

C-BUS

DRU 41.

RUNIVERSAL CONTROLLER WITH

WITH RELAY OUTPUT 0...10 V DC

It controls temperature or other physical properties such as pressure, level, etc.

- passive temperature sensor input or 0...10 Volt DC, from other active sensors
- outputs: 3-point modulating command, 2-stage On-Off or 0...10 Volt dc.

ESSENTIAL SENSORS: 1 passive or active sensor

OPTIONAL SENSORS AND ACCESSORIES: 1 temperature set point adjuster

DRU 414	Universal controller, 24 V AC power supply
DRU 418	Universal controller, 230 V AC power supply

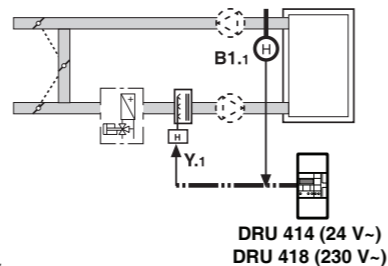

PROTOCOLS FOR COMMUNICATION

OPTIONAL

C-BUS

XTA 624

TEMPERATURE CONTROLLER FOR AIR HANDLING UNIT WITH 2 BATTERIES

OPTIONAL REMOTE CONTROL

Suitable for ambient and/or air flow temperature control in Air Handling Units consisting of:

- 1 or 2 heating and/or cooling batteries
- 1 air mixing unit (dampers) or 1 heat recovery unit

ESSENTIAL SENSOR: 1 room or air duct temperature sensor

OPTIONAL SENSORS AND ACCESSORIES:

- 1 flow sensor,
- 1 outside sensor,
- 1 preheating sensor
- 1 temperature set point adjuster

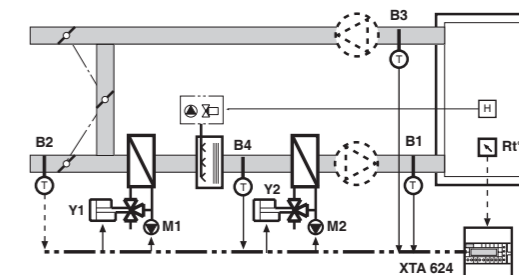

RELATED PRODUCT

ACB 400	Plug-in for communication via C-Bus
ACD 655	Front panel mounting accessory



PROTOCOLS FOR COMMUNICATION

C-BUS C-RING

DPS 638

CONTROLLER FOR SOLAR PANELS

INSTALLATIONS WITH C-BUS REMOTE MONITORING

Automation of solar panel systems with up to 3 storage tanks

- On-Off setting of the thermal integration circuit
- Modulating control of the domestic hot water distribution temperature

ESSENTIAL SENSORS: 1 passive or active sensor

OPTIONAL SENSORS AND ACCESSORIES: 1 temperature set point adjuster

RELATED PRODUCT

ACD 655	Front panel mounting accessory
---------	--------------------------------

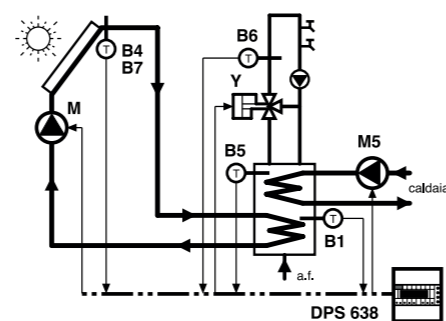



XTU 614

TEMPERATURE AND HUMIDITY CONTROLLER
FOR AIR HANDLING UNIT WITH 1 BATTERY
OPTIONAL REMOTE MONITORING

Suitable for winter and summer control of room temperature and humidity and/or flow air in air handling systems consisting of :

- 1 heating and/or cooling or preheating battery
- 1 On-Off humidification unit
- 1 air mixing unit (dampers) or 1 heat recovery unit
- 1 heat recuperator

PROTOCOLS FOR COMMUNICATION

OPTIONAL

C-BUS

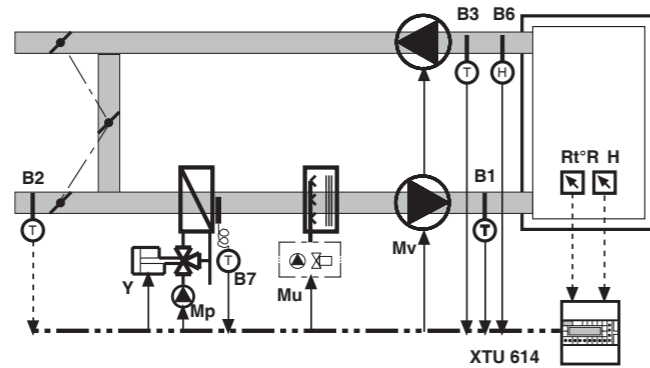

- ESSENTIAL SENSOR: 1 room or air duct temperature sensor
- OPTIONAL SENSORS AND ACCESSORIES:
- 1 flow or pre-heating sensor
 - 1 outside sensor
 - 1 room/Air duct relative humidity sensor
 - 1 battery frost protection sensor
 - 1 temperature set point adjuster
 - 1 humidity set point adjuster

RELATED PRODUCTS

ACB 460	Plug-in for communication via C-Bus
ACD 655	Front panel mounting accessory



XTU 644

TEMPERATURE AND HUMIDITY CONTROLLER
FOR AIR HANDLING UNIT
WITH 2 BATTERIES
OPTIONAL REMOTE MONITORING

Suitable for winter and summer control of room temperature and humidity and/or flow air in air handling systems consisting of:

- 2 heating and/or cooling or preheating batteries
- 1 On-Off humidification unit
- 1 air mixing unit (dampers) or 1 heat recuperator

- ESSENTIAL SENSOR: 1 room or air duct temperature sensor
- OPTIONAL SENSORS AND ACCESSORIES:
- 1 flow temperature sensor
 - 1 outside sensor
 - 1 air duct ambient relative humidity sensor
 - 1 outside relative humidity sensor
 - 1 window sensor, 1 temperature set point adjuster
 - 1 relative humidity set point adjuster

RELATED PRODUCTS

ACB 460	Plug-in for communication via C-Bus
ACD 655	Front panel mounting accessory

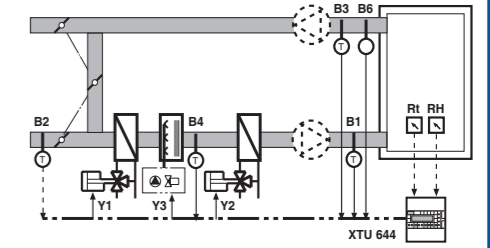

XTU 614/644

TEMPERATURE AND HUMIDITY CONTROLLER
FOR AIR HANDLING UNIT WITH 3 BATTERIES
OPTIONAL REMOTE MONITORING

These are 2 coupled standard 3-battery controllers for Air Handling Unit, consisting of:

- 3 heating/pre-heating, cooling and post-heating batteries
- 1 On-Off humidification unit or 1 heat recovery unit in a single package

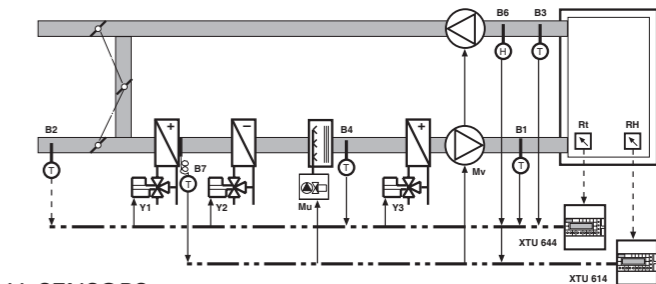

- ESSENTIAL SENSORS: see XTU 614 and XTU 644 controllers
- SENSORS AND ACCESSORIES: see XTU 614 and XTU 644 controllers

RELATED PRODUCTS

ACB 460	Plug-in for communication via C-Bus
ACD 655	Front panel mounting accessory



PROTOCOLS FOR COMMUNICATION

OPTIONAL

C-BUS

XTU 664

TEMPERATURE AND HUMIDITY CONTROLLER
FOR AIR HANDLING UNIT
WITH 2 BATTERIES WITH TIME PROGRAMMING
OPTIONAL REMOTE MONITORING

Suitable for adjustment the ambient and/or air flow temperature in Air Handling Units consisting of:

- 1 or 2 heating and/or cooling batteries
- 1 modulating or On-Off humidification unit
- 1 air mixing unit (dampers) or 1 heat recovery unit
- 1 ventilation unit

IT IS A UNIT SIMILAR TO XTU 644, BUT WITH FULL TIME PROGRAMMING.

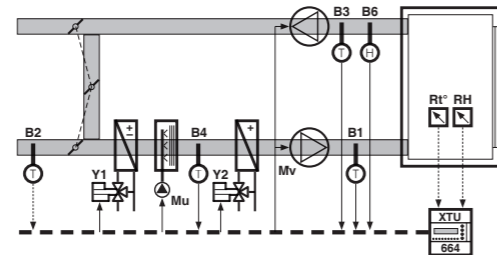

ESSENTIAL SENSORS: 1 room or Air duct temperature sensor

OPTIONAL SENSORS AND ACCESSORIES: 1 flow temperature sensor
1 pre-heating sensor, 1 outside sensor
1 room/Air duct relative humidity sensor
1 outside relative humidity sensor
1 window sensor, 1 temperature variator
1 relative humidity variator

RELATED PRODUCTS

ACB 460	Plug-in for communication via C-Bus
ACD 655	Front panel mounting accessory



RQA 410

AIR QUALITY CONTROLLER

Adjusts the percentage of outside air introduced into the room according to the air quality measured by 1 or more sensors.

CANNOT BE USED FOR FIRE PROTECTION SYSTEMS, GAS LEAK DETECTION OR SIMILAR

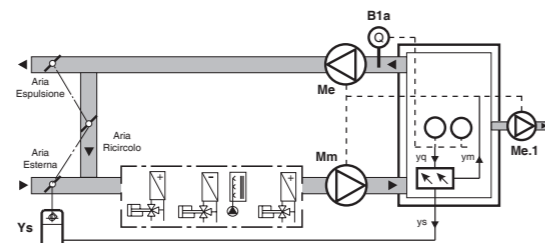

ESSENTIAL SENSOR: 1 or more sensors
1 room or air duct quality sensor

RELATED PRODUCTS

SQC 954	Room air quality sensor
SQS 954	Air quality for air duct

ROOM CONTROL

"MULTIZONE" room temperature control and distribution system

MRL 608

CENTRAL CONTROL UNIT DISPLAY AND MANAGEMENT

Communication master with peripheral units.



PROTOCOLS FOR COMMUNICATION

OPTIONAL

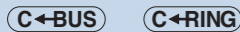

RELATED PRODUCTS

ACB 400	Plug-in for communication via C-Bus
ALD 018	Auxiliary power supply for 50 zones (25 with RTL 120 - 520 room controller)
ACD 655	Front panel mounting accessory



PROTOCOLS FOR COMMUNICATION

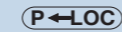

RTL 111

FLUSH-MOUNTED ROOM CONTROLLER FOR 2 PIPE FAN COILS WITH EXPANSION UNIT DEP 658

Room temperature controller via:

- fan coil with On-Off valve and fan with up to 3 speeds
- fan coil with modulating valve and fan up to 3 speeds
- single battery air handling unit and fan.

EXPANDER

DEP 658	Output expander for RTL 111 - 511 room controllers
----------------	--



PROTOCOLS FOR COMMUNICATION



RTL 110

LOCAL (SLAVE) UNIT WITH RELAY OUTPUT, FLUSH MOUNTING

Room temperature controller via an On-Off switch..



PROTOCOLS FOR COMMUNICATION



RTL 511

WALL-MOUNTED ROOM CONTROLLER FOR 2 PIPE FAN COILS WITH EXPANSION UNIT DEP 658

Room temperature controller via:

- fan coil with On-Off valve and fan with up to 3 speeds
- fan coil with modulating valve and fan up to 3 speeds
- single battery air handling unit and fan

EXPANDER

DEP 658	Output expander for RTL 111 - 511 room controllers
----------------	--



PROTOCOLS FOR COMMUNICATION

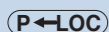

RTL 510

LOCAL (SLAVE) UNIT WITH RELAY OUTPUT, WALL MOUNTING

Wall-mounting room controller with relay output, colour white.



PROTOCOLS FOR COMMUNICATION

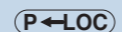

RTL 141

FLUSH-MOUNTED ROOM CONTROLLER FOR 4-PIPE FAN COIL WITH EXPANSION UNIT

Room temperature controller via:

- fan coil with On-Off valve and fan with up to 3 speeds
- fan coil with modulating valve and fan up to 3 speeds
- air handling unit with 2 batteries and fan

EXPANDERS

DEP 648	Output expander for RTL 141 - 541 room controllers
DEP 678	Output expander for RTL 141 - 541 room controllers



PROTOCOLS FOR COMMUNICATION



RTL 120

LOCAL (SLAVE) UNIT WITH RELAY OUTPUT, AND 0...10V DC, FLUSH MOUNTING

Flush-mounting room controller with relay output or 0...10 V DC.



PROTOCOLS FOR COMMUNICATION

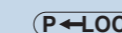

RTL 541

WALL-MOUNTED ROOM CONTROLLER FOR 4-PIPE FAN COIL WITH EXPANSION UNIT

Wall-mounting room controller for expansion units. Colour white

Room temperature controller via:

- fan coil with On-Off valve and fan with up to 3 speeds
- fan coil with modulating valve and fan up to 3 speeds
- air handling unit with 2 batteries and fan.

EXPANDERS

DEP 648	Output expander for RTL 141 - 541 room controllers
DEP 678	Output expander for RTL 141 - 541 room controllers



PROTOCOLS FOR COMMUNICATION



RTL 520

LOCAL (SLAVE) UNIT WITH RELAY OUTPUT, AND 0...10V DC, WALL MOUNTING

Wall-mounting room controller with relay output or 0...10 V DC.

White colour.



PROTOCOLS
FOR COMMUNICATION

P←LOC

DEP 648

EXPANSION UNIT WITH:

- 1 ANALOGUE INPUT
- 4 TRIAC OUTPUTS,
- 3 INTELKED RELAY OUTPUTS

Output expander for RTL 141 - 541

With triac outputs for heating and cooling actuators and relay outputs for On-Off fan with 1 to 3 speeds

RELATED PRODUCT

ACD 655 Front panel mounting accessory



PROTOCOLS
FOR COMMUNICATION

P←LOC

DEP 658

OUTPUT EXPANSION UNIT FOR RTL 111-511

Output expander for RTL 111 - 511 room controllers RTL 111 - 511

RELATED PRODUCT

ALD 110 Accessory to control up to 10 DEP 658 with a single RTL 111-511

ACD 655 Front panel mounting accessory



PROTOCOLS
FOR COMMUNICATION

P←LOC

DEP 678

EXPANSION UNIT WITH:

- 1 ANALOGUE INPUT
- 4 TRIAC OUTPUTS,
- 3 INTERLOCKED RELAY OUTPUTS

Output expander for RTL 141 - RTL 541 with 1 analogue input, 4 relay outputs, 3 interlocked relay outputs

RELATED PRODUCT

ACD 655 Front panel mounting accessory



PROTOCOLS
FOR COMMUNICATION

OPTIONAL

C←BUS

P←LOC

UPM 678

CONTROL UNIT FOR PUMPS, BURNERS, CHILLERS
OR OTHER EQUIPMENT

Control unit for pumps, burners, chillers or other equipment according to the thermal and/or cooling load of the zones

RELATED PRODUCTS

ACB 400 Plug-in for communication via C-Bus

ACD 655 Front panel mounting accessory



DOMESTIC HOT WATER MIXING



MAS 6../T

ELECTRONIC MIXING VALVES FOR DHW WITH REMOTE MONITORING OPTION

FROM 1/2" TO 1"1/4

MAS 7../T

ELECTRONIC MIXING VALVES FOR DHW WITH REMOTE METERING OPTION FROM 1"1/2 TO 2"

Compact unit suitable for fixed-point temperature control in domestic hot water distribution circuits remote control option via ModBus.

PROTOCOLS FOR COMMUNICATION

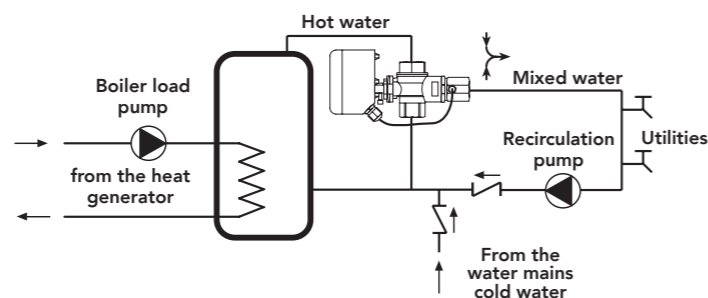

	DN		Flow rate l/min ⁽¹⁾	Kvs m ³ /h ⁽²⁾	Setting range
	Inches	mm			
MAS 615/T	1/2"	15	40	2.5	30 ... 70 °C
MAS 620/T	3/4"	20	70	5	
MAS 625/T	1"	25	130	9	
MAS 632/T	1"1/4	32	180	13.5	
MAS 740/T	1"1/2	40	270	19.2	
MAS 750/T	2"	50	390	28.9	

RELATED PRODUCTS

TMT 500	Additional sealing component for MAS 615/T, which can be installed without removing the valve from the hydraulic system. This sealing component is treated as a spare part
TMT 600	Additional sealing component for MAS 620/T...632/T, which can be installed without removing the valve from the hydraulic system. This sealing component is treated as a spare part
TMT 700	Additional sealing component for MAS 7../T, which can be installed without removing the valve from the hydraulic system. This sealing component is treated as a spare part

(1) Flow rate at an average pressure of 4 bar and a pressure drop of approx. 20%.

(2) Flow coefficient in m³ with valve open with a pressure drop of 100 KPa.



MAS 6../T/AL

ELECTRONIC MIXING VALVES FOR DHW WITH ANTILEGIONELLA FUNCTION AND REMOTE MONITORING OPTION FROM 1/2" TO 1"1/4

MAS 7../T/AL

ELECTRONIC MIXING VALVES FOR DHW WITH ANTILEGIONELLA FUNCTION AND REMOTE MONITORING OPTION FROM 1"1/2 TO 2"

Compact unit suitable for adjusting the fixed-point temperature in domestic hot water distribution circuits with antilegionella function and remote control option via ModBus. It can be integrated into the system.

PROTOCOLS FOR COMMUNICATION

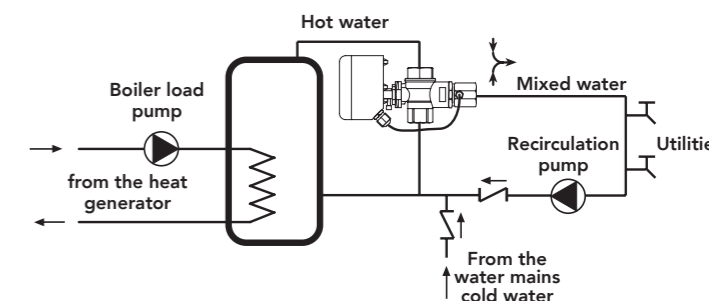

	DN		Flow rate l/min ⁽¹⁾	Kvs m ³ /h ⁽²⁾	Setting range
	Inches	mm			
MAS 615/T/AL	1/2"	15	40	2,5	30 ... 70 °C
MAS 620/T/AL	3/4"	20	70	5	
MAS 625/T/AL	1"	25	130	9	
MAS 632/T/AL	1"1/4	32	180	13.5	
MAS 740/T/AL	1"1/2	40	270	19.2	
MAS 750/T/AL	2"	50	390	28.9	

RELATED PRODUCTS

TMT 500	Additional sealing component for MAS 615/T, which can be installed without removing the valve from the hydraulic system. This sealing component is treated as a spare part
TMT 600	Additional sealing component for MAS 620/T...632/T, which can be installed without removing the valve from the hydraulic system. This sealing component is treated as a spare part
TMT 700	Additional sealing component for MAS 7../T, which can be installed without removing the valve from the hydraulic system. This sealing component is treated as a spare part

(1) Flow rate at an average pressure of 4 bar and a pressure drop of approx. 20%.

(2) Flow coefficient in m³ with valve open with a pressure drop of 100 KPa.



MAS 6..

ELECTRONIC MIXING VALVES FOR DHW
FROM 1/2" TO 1"/1/4

MAS 7..

ELECTRONIC MIXING VALVES FOR DHW
FROM 1"/1/2 TO 2"

Compact unit suitable for fixed-point temperature control in domestic hot water distribution circuits.

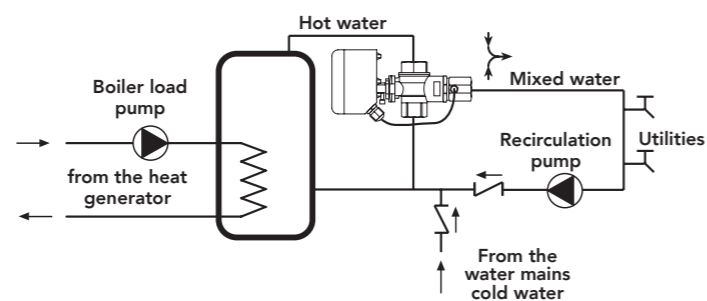

	DN inches	mm	Flow rate l/min ⁽¹⁾	Kvs m ³ /h ⁽²⁾	Setting range
MAS 615	1/2"	15	40	2.5	30 ... 70 °C
MAS 620	3/4"	20	70	5	
MAS 625	1"	25	130	9	
MAS 632	1"1/4	32	180	13.5	
MAS 740	1"1/2	40	270	19.2	
MAS 750	2"	50	390	28.9	

RELATED PRODUCTS

TMS 500	Additional sealing component for MAS 615, which can be installed without removing the valve from the hydraulic system. This sealing component is treated as a spare part
TMS 600	Additional sealing component for MAS 620...632, which can be installed without removing the valve from the hydraulic system. This sealing component is treated as a spare part
TMS 700	Additional sealing component for MAS 7.., which can be installed without removing the valve from the hydraulic system. This sealing component is treated as a spare part

⁽¹⁾ Flow rate with an average pressure of 4 bar and a pressure drop of approx. 20%

⁽²⁾ Flow coefficient in m3 with open valve with pressure drop of 100 KPa



MAS 6..AL

ELECTRONIC MIXING VALVES FOR DHW
WITH ANTILEGIONELLA FUNCTION
FROM 1/2" TO 1"/1/4

MAS 7..AL

ELECTRONIC MIXING VALVES FOR DHW
WITH ANTILEGIONELLA FUNCTION
FROM 1"/1/2 TO 2"

Compact unit suitable for fixed-point temperature control in domestic hot water distribution circuits, with anti-legionella function and open manifold output.

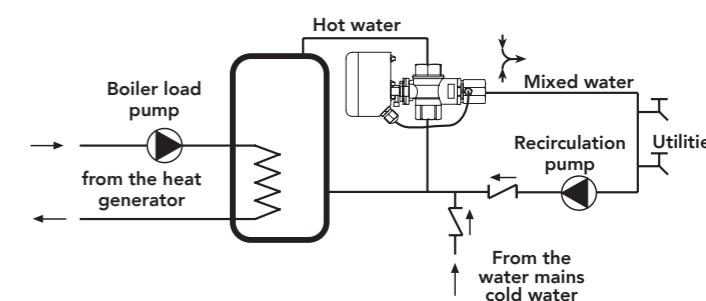

	DN inches	mm	Flow rate l/min ⁽¹⁾	Kvs m ³ /h ⁽²⁾	Setting range
MAS 615/AL	1/2"	15	40	2.5	30 ... 70 °C
MAS 620/AL	3/4"	20	70	5	
MAS 625/AL	1"	25	130	9	
MAS 632/AL	1"1/4	32	180	13.5	
MAS 740/AL	1"1/2	40	270	19.2	
MAS 750/AL	2"	50	390	28.9	

RELATED PRODUCTS

IPS 328	Device for generating 2 alarms through open manifold contact
TMS 500	Additional sealing component for MAS 615, which can be installed without removing the valve from the hydraulic system. This sealing component is treated as a spare part
TMS 600	Additional sealing component for MAS 620...632, which can be installed without removing the valve from the hydraulic system. This sealing component is treated as a spare part
TMS 700	Additional sealing component for MAS 7.., which can be installed without removing the valve from the hydraulic system. This sealing component is treated as a spare part

⁽¹⁾ Flow rate with an average pressure of 4 bar and a pressure drop of approx. 20%

⁽²⁾ Flow coefficient in m3 with open valve with pressure drop of 100 KPa





GAS SAFETY



PROTOCOLS FOR COMMUNICATION



RFG 442 - 448

GAS LEAK DETECTOR WITH UP TO 3 REMOTE SENSORS FOR CENTRAL HEATING PLANT OR SIMILAR

Suitable for detecting methane, LPG or CO leaks. Capable of serving up to 3 external methane, LPG or CO sensors. 4 relay outputs for controlling gas shut-off valves and/or alarms. 4 module DIN enclosure

ESSENTIAL SENSORS: 1 sensor for methane, LPG or carbon monoxide CO.

		Power supply
RFG 442	Gas leak detector for up to 3 remote sensors	12V...24V AC
RFG 448	Gas leak detector for up to 3 remote sensors	230V AC

RELATED PRODUCTS

SRD 150	Civil wall-mounting methane gas sensor
SRD 250	Civil wall-mounting LPG gas sensor
SRS 150	Wall-mounting methane gas sensor for Central heating plant
SRS 350	Wall-mounting LPG gas sensor for Central heating plant
ACD 455	4 DIN adapter

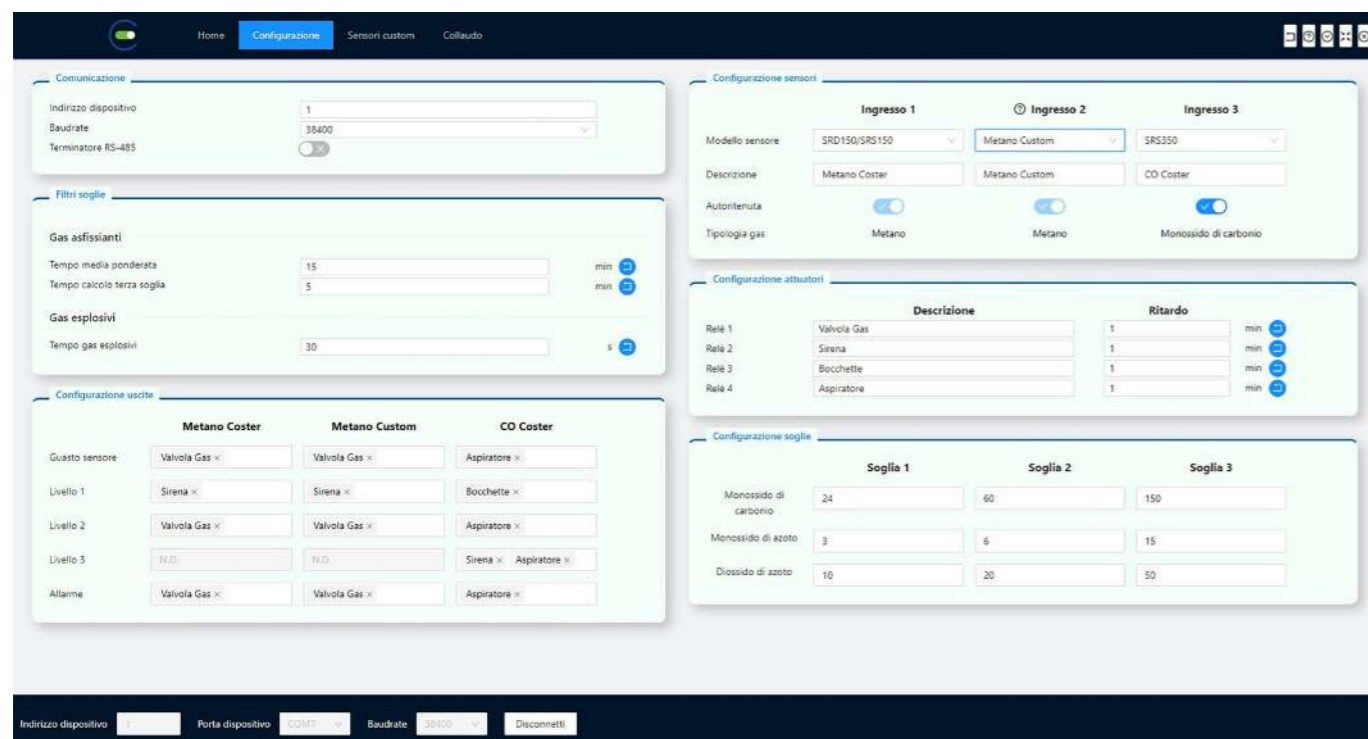

RFG 44x can be configured using the dedicated commissioning and maintenance tool within the CosterTools suite. Specifically, it is possible to:

- To view the status of alarms, inputs, actuators and device data
- Manage communication parameters
- Manage alarm filter times and thresholds
- Configure the actuators
- Enable and configure custom sensors



Gas Leak Detector for domestic use 'DOMOGAS

DGD 1.2..

DOMESTIC GAS LEAK DETECTORS

WITH OUTPUT RELAY

Suitable for detecting methane or LPG gas leaks with the possibility of controlling a solenoid valve (N.C. or N.O.). Interchangeable pre-calibrated sensor..

The detectors comply with CEI EN 50194-1 standards and carry the IMQ quality mark

DGD 118	Methane gas leak detector
DGD 218	LPG gas leak detector



DGD 14-24.

DOMESTIC GAS LEAK DETECTORS

COMPLETE WITH N.O. (NORMALLY OPEN) VALVE WITH MANUAL RESET

These are gas leak detectors, for methane or LPG, complete with gas valve, NORMALLY OPEN, with manual reset at 230V AC.

Interchangeable pre-calibrated sensor.

The detectors comply with CEI EN 50194-1 standards and carry the IMQ quality mark.

DGD 148.15	Methane gas leak detector with 1/2" valve (GARO 815)
DGD 148.20	Methane gas leak detector with 3/4" valve (GARO 820)
DGD 148.25	Methane gas leak detector with 1" valve (GARO 825)
DGD 248.15	LPG gas leak sensor with 1/2" valve (GARO 815)
DGD 248.20	LPG gas leak sensor with 3/4" valve (GARO 820)
DGD 248.25	LPG gas leak sensor with 1" valve (GARO 825)



DGD 318

DOMESTIC CO (CARBON MONOXIDE)

WITH STORAGE AND RELAY OUTPUT

Carbon monoxide detector, with the ability to directly control solenoid valves, valves and other 230V AC actuators.

The detector complies with CEI EN 50291-1.



ACC ...

BATTERIES

Long-life sealed rechargeable batteries. They withstand heavy operating conditions such as overcharging and very low discharge. They are maintenance-free..

	Power VA	Voltage V DC	Ampere capacity per hour	Dimensions LxPxH	Weight Kg
ACC 019	25	12	2.3	178x34x65	0.9
ACC 060	77		7.0	151x64,5x97,5	2.5
ACC 150	180		17	181x76x167	6
ACC 240	260		24	175x166x125	8.1
ACC 400	480		40	197x165x170	14

Method of choosing power supply according to the system to be energised

- Calculate the total power absorbed Pt in VA in the system to be powered by adding up all the consumption values of the individual system components: detectors Pr, sensors Ps (SRS only ...), valves Pv, external alarms Pa. The absorption values of the SGC, SGR sensors do not have to be taken into account as they are already calculated in the detectors powering them.
 $P_t = P_r + P_s + P_v + P_a$. The power supply must be greater than or equal to Pt.
- Multiply the power absorbed Pt by the number of hours h you want to keep the system running without mains supply, and the effective power Pe required is obtained.
 $P_e = P_t \times h$. The power of the battery must not be less than Pe.
 If a single battery is not sufficient, use two or more batteries in parallel.



GENERAL ACCESSORIES

FOR GAS DETECTION SYSTEM

SAS 880	Remote audible alarm
SAL 881	Remote visual alarm
CSL 882	Remote visual and audible alarm



GCAO ...

NORMALLY CLOSED GAS SOLENOID VALVE WITH BRASS BODY

Without power supply they are closed, with power supply they are open. Class A Group 2 approval..

	DN	Power supply		P max ⁽¹⁾ mbar	Flow rate m ³ /h ⁽²⁾	
		V	VA		05 m ³ /h	1 mbar
GCAO 210	3/8"	12 VDC	8.5	200	0.92	1.4
GCAO 410		24 VAC	7			
GCAO 810		230 VAC	9			
GCAO 215	1/2"	12 VDC	8.5			
GCAO 415		24 VAC	7			
GCAO 815		230 VAC	9			
GCAO 220	3/4"	12 VDC	8.5			
GCAO 820		230 VAC	9			
GCAO 420		24 VAC	7			



AL.

BACK UP POWER UNIT FOR GAS SAFETY SYSTEM

Used to supply 12 V DC power to gas safety systems even in the event of a mains power failure.

Composed of:

- 1 stabilised back-up power supply unit.
- 1 watertight accumulator.

STABILISED POWER BACK UP UNITS

Stabilised back-up units for keeping batteries charged

	Power VA	Input V AC	Output V DC	ampere	Dimensions LxPxH	Weight Kg
ALI 310	30	230	13.8	2.25	130x100x38	0.5
ALP 114	90			6.75	200x260x110	6.7
ALP 120	120			9	185x290x130	8

(1) Maximum operating pressure

(2) Natural gas flow rates with 0.5 mbar pressure drop (5 mm CA) and 1 mbar (10 mm WG) 100 mbar=10kPA=1,000 mmWG



GCRO ...

NORMALLY CLOSED GAS SOLENOID VALVES
WITH MANUAL RESET
AND BRASS BODY

With no power supply they are closed, they are open with manual reset and remain open only when powered.
Class A Group 2 approval.

	DN	Power supply		P max ⁽¹⁾ mbar	Flow rate m ³ /h ⁽²⁾	
		V	VA		05 m ³ /h	1 mbar
GCRO 215	1/2"	12 VDC	8	500	1.8	2.6
GCRO 415		24 VAC				
GCRO 815		230 VAC				
GCRO 220	3/4"	12 VDC	8		3	4.5
GCRO 420		24 VAC				
GCRO 820		230 VAC				
GCRO 225	1"	12 VDC	8		4.5	6.6
GCRO 425		24 VAC				
GCRO 825		230 VAC				



GCR ...

NORMALLY CLOSED GAS SOLENOID VALVE
WITH MANUAL RESET
AND ALUMINUM BODY

With no power supply they are closed, they are open with manual reset and remain open only when powered. Class A Group 2 approval

THREADED	DN	Power supply		P max ⁽¹⁾ mbar	Flow rate m ³ /h ⁽²⁾	
		V	VA		05 m ³ /h	1 mbar
GCR 215	1/2"	12 VDC	8	500	6.6	8.7
GCR 415		24 VAC				
GCR 815		230 VAC				
GCR 220	3/4"	12 VDC	8		9.8	14
GCR 420		24 VAC				
GCR 820		230 VAC				
GCR 225	1"	12 VDC	8		15	19
GCR 425		24 VAC				
GCR 825		230 VAC				
GCR 232	1 1/4"	12 VDC	8		18	27
GCR 432		24 VAC				
GCR 832		230 VAC				
GCR 240	1 1/2"	12 VDC	8		20	30
GCR 440		24 VAC				
GCR 840		230 VAC				
GCR 250	2"	12 VDC	8		25	37
GCR 450		24 VAC				
GCR 850		230 VAC				



GARO ...

NORMALLY OPEN GAS SOLENOID VALVES
WITH MANUAL RESET
AND BRASS BODY

With no power supply they are open, with power supply they are closed
They open with a manual reset and remain open only if there is no power supply.

	DN	Power supply		P max ⁽¹⁾ mbar	Flow rate m ³ /h ⁽²⁾	
		V	VA		05 m ³ /h	1 mbar
GARO 215	1/2"	12 VDC	6	500	1.8	2.6
GARO 415		24 VAC				
GARO 815		230 VAC				
GARO 220	3/4"	12 VDC	6		3	4.5
GARO 420		24 VAC				
GARO 820		230 VAC				
GARO 225	1"	12 VDC	8		4.5	6.6
GARO 425		24 VAC				
GARO 825		230 VAC				

(1) Maximum operating pressure

(2) Natural gas flow rates with 0.5 mbar pressure drop (5 mm WG) and 1 mbar (10 mm WG)
100 mbar=10kPA=1,000 mmWG

(1) Maximum operating pressure

(2) Natural gas flow rates with 0.5 mbar pressure drop (5 mm WG) and 1 mbar (10 mm WG)
100 mbar=10kPA=1,000 mmWG



GCR ...

NORMALLY CLOSED
GAS SOLENOID VALVES
WITH MANUAL RESET

With no power supply they are closed, they are open with manual reset and remain open only when powered. Class A Group 2 approval

FLANGED	DN	Power supply		P max ⁽¹⁾ mbar	Flow rate m ³ /h ⁽²⁾				
		V	VA		05 m ³ /h	1 mbar			
GCR 265	65	12 VDC	18	500	53	78			
GCR 465		24 VAC	20						
GCR 865		230 VAC	18						
GCR 280	80	12 VDC	18						
GCR 480		24 VAC	20						
GCR 880		230 VAC	18						
GCR 2100	100	12 VDC	18		83	130			
GCR 4100		24 VAC	20						
GCR 8100		230 VAC	18						
GCR 2125	125	12 VDC	18				230	335	
GCR 4125		24 VAC	20						
GCR 8125		230 VAC	18						
GCR 2150	150	12 VDC	18	360	525				
GCR 4150		24 VAC	20						
GCR 8150		230 VAC	18						
GCR 2200	200	12 VDC	18			800			1,200
GCR 4200		24 VAC	20						
GCR 8200		230 VAC	18						
GCR 2300	300	12 VDC	18	800	1,200				
GCR 4300		24 VAC	20						
GCR 8300		230 VAC	18						

SPECIAL VERSION

GCR .../C Complete with closing indicator microswitch kit

RELATED PRODUCTS

FCR 65-80 Closing indicator microswitch kit for GCR solenoid valves GCR DN 65-80

FCR 100-125-150 Closing indicator microswitch kit for GCR DN 100-125-150 solenoid valve

FCR 200 Closing indicator microswitch kit for GCR solenoid valves GCR DN 200

⁽¹⁾ Maximum operating pressure

⁽²⁾ Natural gas flow rates with 0.5 mbar pressure drop (5 mm CA) and 1 mbar (10 mm WG)
100 mbar=10kPA=1,000 mmWG



GAR ...

NORMALLY OPEN
GAS SOLENOID VALVES
WITH MANUAL RESET

With no power supply they are open, with power supply they are closed. They open with a manual reset and remain open only if there is no power supply.

THREADED	DN	Power supply		P max ⁽¹⁾ mbar	Flow rate m ³ /h ⁽²⁾			
		V	VA		05 m ³ /h	1 mbar		
GAR 232	1 1/4"	12 VDC	20	500	20	29		
GAR 432		24 VAC	22					
GAR 832		230 VAC	23					
GAR 240	1 1/2"	12 VDC	20				25	37
GAR 440		24 VAC	22					
GAR 840		230 VAC	23					
GAR 250	2"	12 VDC	20		25	37		
GAR 450		24 VAC	22					
GAR 850		230 VAC	23					

⁽¹⁾ Maximum operating pressure

⁽²⁾ Natural gas flow rates with 0.5 mbar pressure drop (5 mm WG) and 1 mbar (10 mm WG)
100 mbar=10kPA=1,000 mmWG



GAR ...

NORMALLY OPEN
GAS SOLENOID VALVES
WITH MANUAL RESET

With no power supply they are open, with power supply they are closed.
They open with a manual reset and remain open only if there is no power supply.

FLANGED	DN	Power supply		P max ⁽¹⁾ mbar	Flow rate m ³ /h ⁽²⁾			
		V	VA		05 m ³ /h	1 mbar		
GAR 265	65	12 VDC	20	500	63	92		
GAR 465		24 VAC	22					
GAR 865		230 VAC	23					
GAR 280	80	12 VDC	20		76	115		
GAR 480		24 VAC	22					
GAR 880		230 VAC	23					
GAR 2100	100	12 VDC	20				92	140
GAR 4100		24 VAC	22					
GAR 8100		230 VAC	23					
GAR 2125	125	12 VDC	20		275	400		
GAR 4125		24 VAC	22					
GAR 8125		230 VAC	23					
GAR 2150	150	12 VDC	20				360	525
GAR 4150		24 VAC	22					
GAR 8150		230 VAC	23					
GAR 2200	200	12 VDC	40		790	1.200		
GAR 4200		24 VAC	45					
GAR 8200		230 VAC	57					
GAR 2300	300	12 VDC	40					
GAR 4300		24 VAC	45					
GAR 8300		230 VAC	57					



OPTIONS:
The following versions are also available: DN 250 / DN 300

- (1) Maximum operating pressure
- (2) Natural gas flow rates with 0.5 mbar pressure drop (5 mm WG) and 1 mbar (10 mm WG)
100 mbar=10kPA=1,000 mmWG
- (3) Starting power consumption
- (4) Complete with closing indicator microswitch

GCA ...

AUTOMATIC NORMALLY CLOSED GAS SOLENOID VALVES
AND ALUMINUM BODY

With no power supply they are closed, with power supply they are open.
Class A Group 2 approval.
DN 250 and 300 Class B Group 2 approval.

THREADED	DN	Power supply		P max ⁽¹⁾ mbar	Flow rate m ³ /h ⁽²⁾			
		V	VA		05 m ³ /h	1 mbar		
GCA 215	1/2"	12 VDC	16	200	3.5	5		
GCA 415		24 VAC	14					
GCA 815		230 VAC	18					
GCA 220	3/4"	12 VDC	16		4.8	7		
GCA 420		24 VAC	14					
GCA 820		230 VAC	18					
GCA 225	1"	12 VDC	6/23 ⁽³⁾				6	8.8
GCA 425		24 VAC	7/24 ⁽³⁾					
GCA 825		230 VAC	9/30 ⁽³⁾					
GCA 432	1 1/4"	24 VAC	18/68 ⁽³⁾		19	27		
GCA 832		230 VAC	25/89 ⁽³⁾					
GCA 440	1 1/2"	24 VAC	18/68 ⁽³⁾		20	29		
GCA 840		230 VAC	25/89 ⁽³⁾					
GCA 450	2"	24 VAC	18/68 ⁽³⁾		30	43		
GCA 850		230 VAC	25/89 ⁽³⁾					
FLANGED								
GCA 465	65	24 VAC	50/185 ⁽³⁾		360	50	71	
GCA 865		230 VAC	75/290 ⁽³⁾					
GCA 480	80	24 VAC	50/185 ⁽³⁾	56		80		
GCA 880		230 VAC	75/290 ⁽³⁾					
GCA 4100	100	24 VAC	35/120 ⁽³⁾	90		137		
GCA 8100		230 VAC	70/270 ⁽³⁾					
GCA 4125	125	24 VAC	35/120 ⁽³⁾	180		255		
GCA 8125		230 VAC	70/270 ⁽³⁾					
GCA 4150	150	24VAC	35/120 ⁽³⁾				380	550
GCA 8150		230 VAC	70/270 ⁽³⁾					
GCA 4200C ⁽⁴⁾	200	24 VAC	16/75 ⁽³⁾				570	950
GCA 8200C ⁽⁴⁾		230 VAC	19/66 ⁽³⁾					
GCA 4250C ⁽⁴⁾	250	24 VAC	16/75 ⁽³⁾	900		1400		
GCA 8250C ⁽⁴⁾		230 VAC	19/66 ⁽³⁾					
GCA 4300C ⁽⁴⁾	300	24 VAC	33/96 ⁽³⁾					
GCA 8300C ⁽⁴⁾		230 VAC	38/84 ⁽³⁾					

RELATED PRODUCTS

- FCM 15-20-25** Closure indicator microswitch kit for GCA DN 15-20-25
- FCM 32-40** Closure indicator microswitch kit for GCA DN 32-40
- FCM 50** Closure indicator microswitch kit for GCA DN 50
- FCM 65-80** Closure indicator microswitch kit for GCA DN 65-80
- FCM 100** Closure indicator microswitch kit for GCA DN 100
- FCM 125-150** Closure indicator microswitch kit for GCA DN 125-150

FUNCTIONAL CHARACTERISTICS OF GAS SOLENOID VALVES

Type	Operation	Advantages	Disadvantages
Normally closed GCAO... GCA...	Without power supply it closes. With power supply it opens.	Ideal for heating plants. In the event of a gas leak, the detector cuts off the power supply to the valve. Power is only restored by manually resetting the detector. In the event of a power failure, the valve closes; when it resumes, the valve automatically reopens.	Not recommended in kitchens without a thermocouple. In the event of a power failure, the valve closes and the flame goes out; when power resumes, the valve reopens and the gas escapes, causing a dangerous situation.
Normally closed with manual reset GCRO... GCR...	Without power supply it closes. With power supply it opens only with manual action	Maximum safety in every use	Each time the power supply is interrupted, the valve closes. When power is restored, it must be reopened manually. Not suitable for kitchens because, in the event of a power failure, the user tends to reopen the valve by mechanical means. When power is resumed, the security system is no longer operational
Normally open with manual reset GARO ... GAR ...	With power supply it closes. Without power it opens only with manual action	In the kitchen, it allows gas to be used even in the event of a power supply failure. In the heating plant, in the event of a power failure, the valve remains open and the burner safety systems enter into operation. When power is restored, no manual intervention is required to restart the plant.	In the event of a power supply failure, the valve remains open and the gas safety system remains active only when powered by the buffer battery. They are not currently approved.



VALVES AND ACTUATORS



VFC ...

SHUTTER VALVES FOR 2, 3, 4 WAY FAN COILS TO 3/4" MALE THREADED PN 16 (2...95 °C)

	DN body	DN male connections	Kvs ⁽¹⁾ m ³ /h direct	Suitable actuator ATC bar ⁽²⁾	
2 WAY					
VFC 212	15	1/2"	0.63	1	
VFC 213			1.0		
VFC 214			1.6		
VFC 235	20	3/4"	2.5		
VFC 237			3.5		
VFC 238			4.5		
3 WAY					
VFC 312	15	1/2"	0.63	1	
VFC 314			1.6		
VFC 335			2.5		
VFC 338	25	1"	4.5		
4 WAY					
VFC 412	15	1/2"	0.63		1
VFC 413			1.0		
VFC 414			1.6		
VFC 435	20	3/4"	2.5		
VFC 437			3.5		
VFC 438			25	1"	

ATC ...

ELECTRO-THERMAL LINEAR ACTUATORS FOR VFC VALVES

These are the motors used to automation of VFC-type valves.

Motor valve coupling adapter included (VA80)

The actuators are of the electro-thermal type and therefore they are released when the supply voltage fails. VFC valves are normally open. They close when the motor is mounted and there is no power supply.

(1) Kvs: flow coefficient: flow rate in m³/h with open valve and 100 kPa pressure drop. 100 kPa = 10 mWG = 1 bar

(2) bar: maximum differential pressure Δp max. permitted by the actuator

	Power supply 50/60Hz (W)	Control	Force N	Run time	Auxiliary end of run	valves VFC DN
ATC 220	230 V (1W)	On-Off	100	5 min.	–	15-25
ATC 24	24 V (1W)				–	
ATC 220S	230 V (1W)				(230V 1A)	
ATC 24S	24 V (1W)				(24V 1A)	
ATC M24	24 V (1.4 W)	0÷10V CC	–			



HGM - HMM ...

2, 3, 4 WAY ZONE BALL VALVES PN 10 (5...90°C) UP TO 1"

	DN corpo	Kvs ⁽¹⁾ -m ³ /h		Pipe connections		Suitable actuators				
		straight	angle	female	male	CDK 06. CDK 03.	SVK 014/C			
		m ³ /h	m ³ /h			bar ⁽²⁾	sec ⁽³⁾	bar ⁽²⁾	sec ⁽³⁾	
2 WAY										
HGM 210	3/8"	5.4	–	3/8"	3/8"	6	60	6	60	
HGM 215	1/2"	6		1/2"	1/2"					
HGM 220	3/4"	11		3/4"	3/4"					
HGM 225	1"	25.7		1"	1"					
2 WAY										
HMM 210	3/8"	5.4	–	3/8"	3/8"	6	60	6	60	
HMM 215	1/2"	6		1/2"	1/2"					
HMM 220	3/4"	11		3/4"	3/4"					
HMM 225	1"	25.7		1"	1"					
3 WAY										
HMM 320	3/4"	11	3	3 male 3/4"		6	60	6	60	
HMM 325	1"	25.7	6.5	1"		6	60	6	60	
4 WAY										
HMM 410	3/8"	5.4	1.3	4 male 3/8"		6	60	6	60	
HMM 415	1/2"	6	1.5	1/2"						
HMM 420	3/4"	11	3	3/4"						

(1) Kvs: flow coefficient: flow rate in m³/h with open valve and 100 kPa pressure drop. 100 kPa = 10 mWG = 1 bar

(2) bar: maximum differential pressure Δp max. permitted by the actuator

(3) sec: time required for the actuator to make the valve perform its full stroke



CDK ...

ACTUATORS FOR
HGM..., HMM... (1...95°C)

Power supply 230, 24, 12 V AC, 3-point electrical control.
These actuators are provided with auxiliary limit switches and removable terminal block connection.

	Power supply V (VA)	Control	Run time sec.	Nominal Torque Kg/cm (Nm)	Starting Torque Kg/cm (Nm)
CDK 032	12 AC (4)	3 points	30	10 (1)	20 (2)
CDK 034	24 AC (1)				
CDK 038	230 AC (4)				
CDK 062	12 AC (4)		60	15 (1.5)	30 (3)
CDK 064	24 AC (1)				
CDK 068	230 AC (4)				



SVK 014/C

ACTUATOR WITH COSTER LINKAGE FOR HMM VALVES

Power supply 24V AC, electric control at 0-10 V DC.
These actuators are supplied with 1 metre long connection cables

	Power supply V (VA)	Control	Run time sec.	Nominal Torque Nm	Starting Torque Nm
SVK 014/C	24V AC	0...10 VDC	60	2,5	5



ATR 868

WIRELESS ACTUATOR FOR RADIATORS

Actuator powered by 2 AA batteries.
ATR 868 communicates wirelessly with the CSW 868 device, which acquires up to 40 devices.

Suitable for controlling VGT valves ... for radiators.



DGT ...

RADIATOR LOCKSHIELD VALVE PN 10 (5...90 °C)

It is the valve that is installed at the bottom of the radiator, as a lockshield, which cannot be motorised.

STRAIGHT

DGT 110	Radiator lockshield valve DN 3/8"
DGT 115	Radiator lockshield valve DN 1/2"
DGT 120	Radiator lockshield valve DN 3/4"
DGT 110/R	Radiator lockshield valve DN 3/8" for copper pipe connection
DGT 115/R	Radiator lockshield valve DN 1/2" for copper pipe connection

ANGLED

DGT 210	Radiator lockshield valve DN 3/8"
DGT 215	Radiator lockshield valve DN 1/2"
DGT 220	Radiator lockshield valve DN 3/4"
DGT 210/R	Radiator lockshield valve DN 3/8" for copper pipe connection
DGT 215/R	Radiator lockshield valve DN 1/2" for copper pipe connection

RELATED PRODUCTS

AGT 10	Nut with rubber dual-cone for copper pipe connection (10 mm)
AGT 12	Nut with rubber dual-cone for copper pipe connection (12 mm)
AGT 14	Nut with rubber dual-cone for copper pipe connection (14 mm)
AGT 15	Nut with rubber dual-cone for copper pipe connection (15 mm)
AGT 16	Nut with rubber dual-cone for copper pipe connection (16 mm)



VGT ...

RADIATOR CONTROL VALVE PN 10 (5...90 °C)

Standard connection for standardised thermostatic heads, motor-driven.

STRAIGHT

VGT 110	Radiator control valve DN 3/8"
VGT 115	Radiator control valve DN 1/2"
VGT 120	Radiator control valve DN 3/4"
VGT 110/R	Radiator control valve DN 3/8" for copper pipe connection
VGT 115/R	Radiator control valve DN 1/2" for copper pipe connection

ANGLED

VGT 210	Radiator control valve DN 3/8"
VGT 215	Radiator control valve DN 1/2"
VGT 220	Radiator control valve DN 3/4"
VGT 210/R	Radiator control valve DN 3/8" for copper pipe connection
VGT 215/R	Radiator control valve DN 1/2" for copper pipe connection

RELATED PRODUCTS

AGT 10	Nut with rubber dual-cone for copper pipe connection (10 mm)
AGT 12	Nut with rubber dual-cone for copper pipe connection (12 mm)
AGT 14	Nut with rubber dual-cone for copper pipe connection (14 mm)
AGT 15	Nut with rubber dual-cone for copper pipe connection (15 mm)
AGT 16	Nut with rubber dual-cone for copper pipe connection (16 mm)



YDG 2..

BALL VALVES 2 WAY BALL VALVES 2 WAY (-15...120 °C) UP TO 4"
BOTH COSTER GROUP AND EUROPEAN SQUARE FLANGE CONNECTION

General purpose ball shut-off valves. Threaded valves DN 1/2"...4".

	DN	PN	Kvs ⁽¹⁾ m³/h	Suitable actuators		
				CRB .. bar ⁽²⁾	CVC .. bar ⁽²⁾	CVH ... bar ⁽²⁾
YDG 215	1/2"	40	16.3	10	10	-
YDG 220	3/4"		29.5			
YDG 225	1"		43			
YDG 232	1"1/4		89			
YDG 240	1"1/2		230			
YDG 250	2"	265	-	-	10	
YDG 265	2"1/2	540				
YDG 280	3"	873				
YDG 2100	4"	16	1.390	-	-	10



YDG 2../inox

STAINLESS STEEL BALL VALVES 2 WAY PN 64 (-20...160°C) UP TO 2"
WITH REDUCED KVS ON THIRD WAYS

Stainless steel valves for high pressure, and for liquids that require it.
Threaded valves DN 1/2"...2"

	DN	Kvs ⁽¹⁾ m³/h	Suitable actuators	
			CRB ... bar ⁽²⁾	CVH ... bar ⁽²⁾
YDG 215/Inox	1/2"	16.3	10	10
YDG 220 /Inox	3/4"	29.5		
YDG 225 /Inox	1"	43		
YDG 232 /Inox	1"1/4	89		
YDG 240 /Inox	1"1/2	230	-	-
YDG 250 /Inox	2"	265		

YDG 2../A

BALL VALVES 2 WAY BALL VALVES 2 WAY (-15...120 °C) UP TO 4"

BOTH COSTER GROUP AND EUROPEAN SQUARE FLANGE CONNECTION

RANGE FOR ACE 00./P ACTUATOR

General purpose ball shut-off valves. Threaded valves DN 1/2"...4".



	DN	PN	Kvs ⁽¹⁾ m³/h	Suitable actuators
				ACE 00./P bar ⁽²⁾
YDG 215/A	1/2"	40	16.3	10
YDG 220/A	3/4"		29.5	
YDG 225/A	1"		43	
YDG 232/A	1"1/4		89	
YDG 240/A	1"1/2		230	
YDG 250/A	2"		265	



YDG 2../A/inox

STAINLESS STEEL BALL VALVES 2 WAY PN 64 (-20...160°C) UP TO 2"
WITH REDUCED KVS ON THIRD WAYS
RANGE FOR ACE 00./P ACTUATOR

Stainless steel valves for high pressure, and for liquids that require it.
Threaded valves DN 1/2"...2".

	DN	Kvs ⁽¹⁾ m³/h	Suitable actuators
			ACE 00./P bar ⁽²⁾
YDG 215/A/Inox	1/2"	16.3	10
YDG 220/A/Inox	3/4"	29.5	
YDG 225/A/Inox	1"	43	
YDG 232/A/Inox	1"1/4	89	
YDG 240/A/Inox	1"1/2	230	
YDG 250/A/Inox	2"	265	

(1) Kvs: flow coefficient: flow rate in m³/h with open valve and 100 kPa pressure drop. 100 kPa = 10 mWG = 1 bar

(2) bar: maximum differential pressure Δp max. permitted by the actuator

(1) Kvs: flow coefficient: flow rate in m³/h with open valve and 100 kPa pressure drop. 100 kPa = 10 mWG = 1 bar

(2) bar: maximum differential pressure Δp max. permitted by the actuator



XLG 3..

BALL ZONE VALVES
3 WAY PN 6 (-15...120°C)
WITH REDUCED KVS ON THIRD WAYS

XLG 3.. valves are used for diverting water flow in heating or cooling systems.

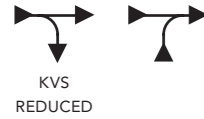

	DN	Kvs ⁽¹⁾ m ³ /h		Suitable actuators		
		straight	angle	CRB ... CVC ... bar ⁽²⁾	CVH 11. CVH 63./21./05 bar ⁽²⁾	CVH 63./21./05 bar ⁽²⁾
XLG 315	1/2"	16.3	1.5	6	6	6
XLG 320	3/4"	29.5	2.7			
XLG 325	1"	43	3.9			
XLG 332	1"1/4	89	7.9			
XLG 341	1"1/2	160	14.8	-	-	-
XLG 351	2"	265	24.5	-	-	-



XDG 3 ..

3 WAY SCREWED FEMALE BALL PN 6 (-15...120°C)
IN DEVIATION AT KVS CONSTANT KVS ON BOTH WAYS

These are general-purpose 3-way valves used for diversion with straight inputs or outputs.
Diverter valves, threaded DN 1/2"...2".



	DN inches	Kvs ⁽¹⁾ m ³ /h	Suitable actuators		
			CRB ... CVC ... bar ⁽²⁾	CVH 11. bar ⁽²⁾	CVH 63./21./05 bar ⁽²⁾
XDG 310	3/8"	1.8	6	6	6
XDG 315	1/2"	3.9			
XDG 320	3/4"	7.9			
XDG 325	1"	13			
XDG 332	1"1/4	20.7	-	-	-
XDG 340	1"1/2	38.7	-	-	-
XDG 350	2"	54	-	-	-



XLG 3../A

BALL ZONE VALVES
3 WAY PN 6 (-15...120°C)
WITH REDUCED KVS ON THIRD WAYS

FOR ACE 00./P ACTUATOR

XLG 3.. valves are used for diverting water flow in heating or cooling systems.

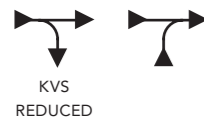

	DN	Kvs ⁽¹⁾ m ³ /h		Suitable actuators
		straight	angle	ACE 00./P bar ⁽²⁾
XLG 315/A	1/2"	16.3	1.5	6
XLG 320/A	3/4"	29.5	2.7	
XLG 325/A	1"	43	3.9	
XLG 332/A	1"1/4	89	7.9	
XLG 341/A	1"1/2	160	14.8	-
XLG 351/A	2"	265	24,5	-



XDG 3../A

3 WAY SCREWED FEMALE BALL PN 6 (-15...120°C)
IN DEVIATION AT KVS CONSTANT KVS ON BOTH WAYS

FOR ACE 00./P ACTUATOR

These are general-purpose 3-way valves used for diversion with straight inputs or outputs.
Diverter valves, threaded DN 1/2"...2".



	DN inches	Kvs ⁽¹⁾ m ³ /h	Suitable actuators
			ACE 00./P bar ⁽²⁾
XDG 310/A	3/8"	1.8	6
XDG 315/A	1/2"	3.9	
XDG 320/A	3/4"	7.9	
XDG 325/A	1"	13	
XDG 332/A	1"1/4	20.7	-
XDG 340/A	1"1/2	38.7	-
XDG 350/A	2"	54	-

(1) Kvs: flow coefficient: flow rate in m³/h with open valve and 100 kPa pressure drop. 100 kPa = 10 mWG = 1 bar

(2) bar: maximum differential pressure Δp max. permitted by the actuator

(1) Kvs: flow coefficient: flow rate in m³/h with open valve and 100 kPa pressure drop. 100 kPa = 10 mWG = 1 bar

(2) bar: maximum differential pressure Δp max. permitted by the actuator



2S

2 WAY BALL VALVES
FLANGED PN 16 (-15...120 °C)

Ball valves, sealed, for shut-off in installations: boilers and other general purposes, DN 40...200..

	DN mm	Kvs ⁽¹⁾ m³/h	Suitable actuators		
			CVH 63./21. bar ⁽²⁾	CVF ... bar ⁽²⁾	CVS 808 bar ⁽²⁾
2S DN 40	40	230	6	-	-
2S DN 50	50	265			
2S DN 65	65	540			
2S DN 80	80	873	-	6	-
2S DN 100	100	1,390			
2S DN 100S	100	1,390			
2S DN 125	125	1,707	-	-	10
2S DN 150	150	2,024			
2S DN 200	200	2,720			



BUTTERFLY

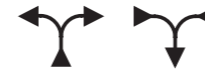

- (1) Kvs: flow coefficient: flow rate in m³/h with open valve and 100 kPa pressure drop. 100 kPa = 10 mWG = 1 bar
- (2) bar: maximum differential pressure Δp max. permitted by the actuator
- (3) Rotor type: for 3-way valves: sector = left or right side way always open; butterfly = central way always open
- (4) Length: flange to flange
- (5) With CVF: coupling only possible with AVF 171 connection
With CVH: direct coupling

VFG ... - VFF ...

3 OR 4 WAY BUTTERFLY VALVES
PN 6 (10...110 °C)

Control valves for circulating water temperature in heating systems, DN 15...150. IN THE 4-WAY THE ROTARY ELEMENT IS ONLY BUTTERFLY

3 WAY THREAD.	DN inches	Kvs ⁽¹⁾ m³/h	Rotor ⁽³⁾	Length ⁽⁴⁾ mm	Suitable actuators		
					CVC ... bar ⁽²⁾	CVH... bar ⁽²⁾	CVF ... bar ⁽²⁾
VFG 320	3/4"	13	butterfly	130	0.3	0.5	-
VFG 325	1"			130			
VFG 332	1"1/4	19		142	0.2		
VFG 340	1"1/2	29		160			
VFG 350	2"	57		190			

3 WAY FLANG.	DN	Kvs ⁽¹⁾	Rotor ⁽³⁾	Length ⁽⁴⁾	CVC ...	CVH...	CVF ...
	inches	m³/h		mm	bar ⁽²⁾	bar ⁽²⁾	bar ⁽²⁾
VFF 340	40	29	butterfly	180	0.2	0.5	-
VFF 350	50	57		200			
VFF 365	65	81		230	0.4		
VFF 380	80	170		250			
VFF 3100	100	240		280	-	0.3	
VFF 3125	125	470	300	-	-	0.5	
VFF 3150	150	700	350	-	-	0.5	

4 WAY THREAD.	DN	Kvs ⁽¹⁾	Rotor ⁽³⁾	Length ⁽⁴⁾	CVC ...	CVH...	CVF ...
	inches	m³/h		mm	bar ⁽²⁾	bar ⁽²⁾	bar ⁽²⁾
VFG 420	3/4"	13	butterfly	130	0.3	0.5	-
VFG 425	1"	13		142			
VFG 432	1"1/4	19		160	0.2		
VFG 440	1"1/2	29		190			
VFG 450	2"	57					

4 WAY FLANG.	DN	Kvs ⁽¹⁾	Rotor ⁽³⁾	Length ⁽⁴⁾	CVC ...	CVH...	CVF ...
	inches	m³/h		mm	bar ⁽²⁾	bar ⁽²⁾	bar ⁽²⁾
VFF 440	40	29	butterfly	180	0.2	0.5	-
VFF 450	50	57		200			
VFF 465	65	81		230	0.4		
VFF 480	80	170		250			
VFF 4100	100	240		280	-	0.3	
VFF 4125	125	470	300	-	-	0.5	
VFF 4150	150	700	350	-	No	0.5	



VSG ... - VSF ...

3 WAY SLIPPER VALVES
PN 6 (10...110°C)

Control valves for circulating water temperature in heating systems, DN 15...150.

3 WAY THREADED	DN inches	Kvs ⁽¹⁾ m³/h	Rotor ⁽³⁾	Length ⁽⁴⁾ mm	Suitable actuators		
					CVC ... bar ⁽²⁾	CVH... bar ⁽²⁾	CVF ... bar ⁽²⁾
VSG 320	3/4"	13	sector	130	0.3	0.5	-
VSG 325	1"			142			
VSG 332	1"1/4	19		160	0.2		
VSG 340	1"1/2	29		190			
VSG 350	2"	57					
3 WAY FLANGED	DN	Kvs ⁽¹⁾	Rotor ⁽³⁾	Length ⁽⁴⁾	CVC ...	CVH...	CVF ...
	mm	m³/h		mm	bar ⁽²⁾	bar ⁽²⁾	bar ⁽²⁾
VSF 340	40	29	sector	180	0.2	0.5	-
VSF 350	50	57		200			
VSF 365	65	81		230	0.4		
VSF 380	80	170		250			
VSF 3100	100	240		280	-	0.3	
VSF 3125	125	470	300	-	No	0.5	
VSF 3150	150	700	350	-	No	0.5	

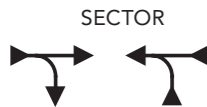

- (1) Kvs: flow coefficient: flow rate in m³/h with open valve and 100 kPa pressure drop. 100 kPa = 10 mWG = 1 bar
- (2) bar: maximum differential pressure Δp max. permitted by the actuator
- (3) Rotor type: for 3-way valves: sector = left or right side way always open; butterfly = central way always open
- (4) Length: flange to flange
- (5) With CVF: coupling only possible with AVF 171 connection
With CVH: direct coupling



2 FT

SEALED BUTTERFLY VALVES

Wafer sealed butterfly valves PN 16, with stainless steel lens. Supplied with manual handle and connections for Coster actuators.

	DN mm	Suitable actuators		
		CVH ...	CVF ...	CVS 808
2FT40	40	•	-	-
2FT50	50	•		
2FT65	65	•		
2FT80	80	-	•	-
2FT100	100		•	
2FT125	125		•	
2FT150	150		•	
2FT200	200		-	



CRB ...

ROTARY ACTUATOR WITH ELECTRIC CABLE

230-24 V AC power supply, 3-point electrical control, 6 Nm torque.

	Power supply V (VA)	Run time sec.	Nominal Torque Kg/cm (Nm)	Starting Torque Kg/cm (Nm)	2S XDG/ XLG/YDG Valves
CRB 098	230 AC (4.5)	90	60 (6)	90 (9)	1" 1/4
CRB 094	24 AC (4.5)				

SPECIAL VERSION

CRB 098/S2 Pack of 1 flange complete with seals, bolts, nuts and washers



CVC ...

ROTARY ACTUATOR WITH ELECTRIC TERMINAL BOX

230-24 V AC power supply, 3-point electrical control, 6 Nm torque.

	P. Supply V (VA)	Run time sec.	Nominal Torque Kg/cm (Nm)	Starting Torque Kg/cm (Nm)	Valves (up to DN)		
					VSG/VFG VSF/VFF mixing	2F butter- fly	XDG/ XLG/YLG ball
CVC 188	230 AC (2.5)	180	60 (6)	90 (9)	50	65	1" 1/4
CVC 184	24 AC (2.5)						
CVC 098	230 AC (4.5)	90	60 (6)	90 (9)	50	65	1" 1/4
CVC 094	24 AC (4.5)						
CVC 038	230 AC (5)	30	60 (6)	90 (9)	50	65	1" 1/4
CVC 034	24 AC (5)						
CVC 018	230 AC (7)	15	60 (6)	90 (9)	50	-	-
CVC 014	24 AC (7)						

SPECIAL VERSIONS AT EXTRA CHARGE

CVC .../T With 6 W heater for fluid applications down to - 15 °C (without auxiliary micro)

RELATED PRODUCT FOR CRB AND CVC

SMP 750	Manual release for VSG/VFG/VSF/VFF mixing valves, 2F butterfly valve and XDG/XLG ball valves
SMP 760	Manual release for ball YDG 2 valves.. up to 1" 1/4
AVA 101	Linkage for: Honeywell-Mut 2 (Controlli, Caleffi, Sara); Zentra; Buche (Cazzaniga, Sauter, Ari-Fasoli, Chibro-Muller, Vilb up to 2", Mastermann); Landis & Gyr (Lazzari, Tonon, Casem); Stark (Besser, Errevi, Interme, Ari - Fasoli)
AVS 103	Linkage for: Honeywell-Mut 3 threaded old model (Controlli, Caleffi, Sara)
AVS 104	Linkage for: Landis & Gyr SN3-SN4



2F

2 WAY BUTTERFLY VALVES SINGLE FLANGE PN 6 (10...110°C)

Single-flange valves for boiler shut-off, DN 50...200.

	DN mm	Kvs ⁽¹⁾ m³/h	Suitable actuators	
			CVC ... bar ⁽²⁾	CVH ... bar ⁽²⁾
2F DN 50	50	100	1.5	3
2F DN 65	65	160		
2F DN 80	80	280		
2F DN 100	100	450	-	2
2F DN 125	125	700		
2F DN 150	150	1.200		
2F DN 200	200	2.300		

⁽¹⁾ Kvs: flow coefficient: flow rate in m³/h with open valve and 100 kPa pressure drop. 100 kPa = 10 mWG = 1 bar

⁽²⁾ bar: maximum differential pressure Δp max. permitted by the actuator



CVH ...

ROTARY ACTUATOR WITH MANUAL RELEASE

230-24V AC power supply, 3-point electrical control, torque 15 Nm.

	Power supply V (VA)	Run time sec.	Valves (up to DN)						
			Nominal Torque Kg/cm (Nm)	Starting Torque Kg/cm (Nm)	VSG/VFG VSF/VFF mixing	2F butter- fly	XDG/ XLG/ ball	YDG 2 ball	2S ball
CVH 054	24 (4.5)	52	150 (15)	200 (20)	100	200	2"	-	-
CVH 058	230 (5)								
CVH 114	24 (4.5)	105					1"1/2	2"1/2	-
CVH 118	230 (4.5)								
CVH 214	24 (4.5)	210					2"	65	
CVH 218	230 (4.5)								
CVH 634	24 (4.5)	630					-	-	-
CVH 638	230 (4.5)								

SPECIAL VERSIONS AT EXTRA CHARGE

CVH .../T	Complete with 2 W internal heater for applications with fluid down to -15 °C
-----------	--

RELATED PRODUCTS

AVA 101	Linkage for: Honeywell-Mut 2 (Controlli, Caleffi, Sara); Zentra; Buche (Cazzaniga, Sauter, Ari-Fasoli, Chibro-Muller, Vilb up to 2", Mastermann); Landis & Gyr (Lazzari, Tonon, Casem); Stark (Besser, Errevi, Interme, Ari - Fasoli)
AVS 103	Linkage for: Honeywell-Mut 3 threaded old model (Controlli, Caleffi, Sara)
AVS 104	Linkage for: Landis & Gyr SN3-SN4



CVS 808

ACTUATOR FOR 2S DN 100s - 200 VALVES

	Power supply V (VA)	Run time sec.	Nominal Torque Kg/cm (Nm)	Starting Torque Kg/cm (Nm)	2S DN Valves
CVS 808	230 AC (120)	55	8.000 (800)	8.000 (800)	100S-200



CVF ...

ROTARY ACTUATOR FOR DN 100...150 VALVES

230-24 V AC power supply, 3-point electrical control, 1 Nm torque.
Standardised connection for Coster valves, except VFF 3100 and VFF 4100.
See accessories table for these valves.

	Power supply V (VA)	Run time sec.	Nominal Torque Kg/cm (Nm)	Starting Torque Kg/cm (Nm)	Valves (up to DN)		
					VSF/VFF mixing	2S butter- fly	YDG 2 ball
CVF 154	24 (7)	150	1,000 (100)	1,000 (100)	100...150	80 / 100	3" / 4"
CVF 158	230 (7)						
CVF 454	24 (6)	450	1,200 (120)	1,200 (120)			
CVF 458	230 (6)						

RELATED PRODUCTS

AVF 171	CVF Linkage for: Coster VFF 3100, VFF 4100 and VSF 3100
AVF 172	CVF linkage for: Honeywell-Mut 2 flanged (Controlli, Caleffi, Sara); Jucker; Zentra; Landis & Gyr (Lazzari, Tonon, Casem); Stark (Besser, Errevi, Interme, Ari-Fasoli); Buche (Cazzaniga, Sauter, Ari-Fasoli, Chibro-Muller, Vilb up to 2", Mastermann)



SVK 014

ACTUATOR WITH ISO CONNECTIONS FOR V-BALL
FROM DN 15 TO DN 25

Power supply 24V AC, electrical control at 0 - 10 V DC.

These actuators are supplied with 1 metre long connection cables

	Power supply	Control	Run time sec.	Nominal Torque Nm	Starting Torque Nm
SVK 014	24V AC	0...10 VDC	60	2,5	5



PROTOCOLS FOR COMMUNICATION



ACE 00./P

INTELLIGENT ACTUATOR FOR V-BALL CONTROL VALVES

Smart actuator coupling with two-way or three-way equipercentual ball valves with ISO 5211:2017 - F03 connection
Driving and control via Modbus protocol or with 0-10V DC or three-point signal. Possible connection in BUS with Modbus/ RTU protocol;
Actuator release knob to allow manual movement of the valve and quick re-engagement of the kinematic chain.

Actuator limit switch auxiliary contacts (total open/close position)

ACE 004/P AVAILABLE FROM APRIL 2026

ACE 004/P	Smart actuator, 24 VAC power supply
ACE 008/P	Smart actuator, 230 VAC power supply

RELATED PRODUCTS

ALM M12	Power supply cable with 220 VAC socket
AUX M12	Auxiliary cable for ACE 00/P
USB M12	Specific USB cable for ACE 00/P programming
AVC 20-100	Connection for three-way slipper valves VSG - VSF or three- or four-way butterfly valves VFG - VFF..
AVX 10-32	Connection for three-way ball valves XLG3.. and XDG 3 (up to DN 32).
AVX 40-50	Connection for ball valves XLG 3.. and XDG 3.. (DN 40-50)
AVY 15-32	Two-way ball connection YDG 2.. and YDG2../inox (DN 15-32)
AVY 40-50	Two-way ball connection YDG 2.. and YDG2../inox (DN 40-50)

Operating mode

ACE 00/P can operate in different modes:

- **0..10VDC positioner (default mode):** the actuator operates as a simple positioner driven by a 0..10VDC signal on the first universal input.
- **3-point positioner:** again, the function is a simple positioner with a 3-point control signal. The opening or closing movement depends on the closure of the first two universal inputs set as digital
- **Modbus positioner:** the actuator control is via Modbus/RTU protocol. A special register is used to set its position from 0% to 100%
- **Modbus temperature controller:** in this case a temperature setpoint is delivered via the Modbus/RTU protocol. ACE 00./p will calculate its position based on an internal controller comparing the setpoint with the temperature measurement taken by the first universal input.
- **Modbus temperature controller with limitation:** this is quite similar to the previous case with a setpoint transferred through a Modbus register and the actuator adjusting its opening/closing based on the temperature detected. In this scenario, however, a temperature limit sensor is also added, which can also be set via Modbus/RTU protocol.

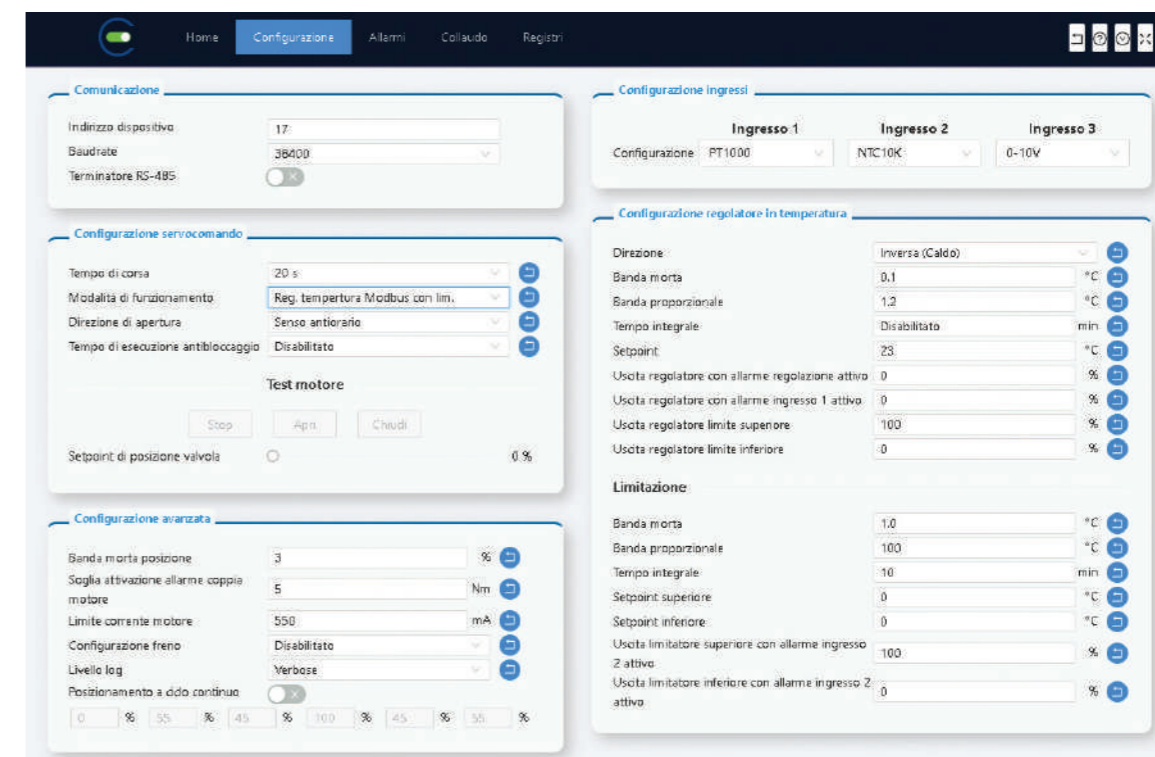

ACE 00./P can be configured via a special commissioning & maintenance tool within the CosterTools suite. Through the configuration sw it is also possible to display some general information about the device, including:

- Inputs status and configuration
- The operating time, the controller output
- Card temperature
- Absorbed current, power and voltage
- The position of the valve, the insertion of the manual release
- Whether or not calibration is taking place
- The status of limit switches and movement

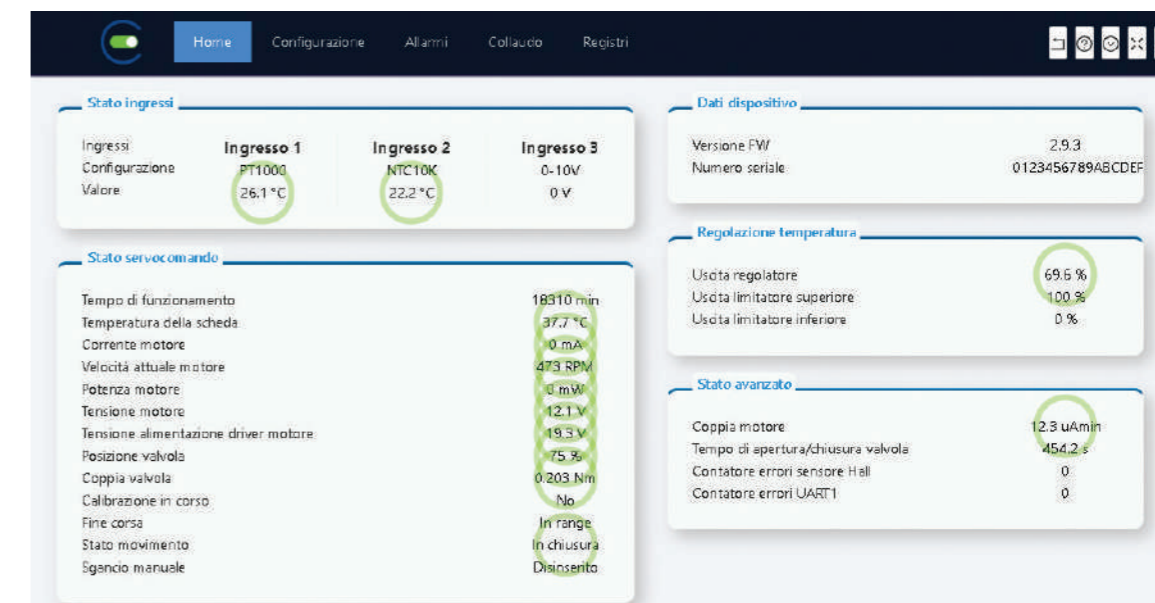



VBR 2..

V-BALL CONTROL VALVES 2 WAYS PN 16

Devices that allow, as the characterisation disc inserted varies, to obtain a certain thermal output with an opening/flow rate curve with an equipcentage trend.

	DN mm	Kvs ⁽¹⁾ m³/h	Suitable actuators	
			ACE 00./P bar ⁽²⁾	SVK 014 bar ⁽²⁾
VBR 215-0,25	15	0.25	2.5	2,5
VBR 215-0,4		0.4		
VBR 215-0,63		0.63		
VBR 215-1		1		
VBR 215-1,6		1.6		
VBR 215-2,5		2.5		
VBR 215-4		4		
VBR 215-6,3		6.3		
VBR 220-4		20		
VBR 220-6,3	6.3			
VBR 220-8,6	8.6			
VBR 220-10	10			
VBR 225-6,3	25	6.3	2.5	1
VBR 225-10		10		
VBR 225-16		16		
VBR 232-10	32	10	2.5	1
VBR 232-16		16		
VBR 232-25		25		
VBR 240-16	40	16	2.5	1
VBR 240-25		25		
VBR 250-25	50	25	2.5	1
VBR 250-40		40		



VBR 3..

V-BALL CONTROL VALVES 3 WAYS PN 16

Devices that allow, as the characterisation disc inserted varies, to obtain a certain thermal output with an opening/flow rate curve with an equipcentage trend.

	DN mm	Kvs ⁽¹⁾ m³/h	Suitable actuators				
			ACE 00./P bar ⁽²⁾	SVK 014 bar ⁽²⁾			
VBR 315-0,25	15	0.25	2.5	2.5			
VBR 315-0,4		0.4					
VBR 315-0,63		0.63					
VBR 315-1		1					
VBR 315-1,6		1.6					
VBR 315-2,5		2.5					
VBR 315-4		4					
VBR 315-6,3		20			6.3	2.5	2.5
VBR 320-4					4		
VBR 320-6,3	6.3						
VBR 320-10	25	10	2.5	1			
VBR 325-6,3		6.3					
VBR 325-10		10					
VBR 325-16	32	16	2.5	1			
VBR 332-10		10					
VBR 332-16		16					
VBR 332-25	40	25	2.5	1			
VBR 340-16		16					
VBR 340-25	50	25	2.5	1			
VBR 350-25		25					
VBR 350-40		40					

(1) Kvs: flow coefficient: flow rate in m³/h with open valve and 100 kPa pressure drop.
100 kPa = 10 mWG = 1 bar

(2) bar: maximum differential pressure Δp max. permitted by the actuator



VYG 615

6-WAYS CONTROL VALVES
INNER THREADING / PN 16 / DN 15

Fluid temperature: 6...80 °C

- (1) Kvs : flow coefficient: flow rate in m³/h with open valve and 100 kPa pressure drop.
100 kPa = 10 mWG = 1 bar
- (2) bar: maximum differential pressure Δp max. permitted by the actuator
- (3) Rotor type: for 3-way valves: sector = left or right side way always open; butterfly = central way always open

	DN		Kvs (Seq. I) m ³ /h	Kvs (Seq. II) m ³ /h	Suitable actuator CVLR ... 90 sec ⁽³⁾ bar ⁽²⁾		
	mm	inches					
VYG 615 - 0,25 - 0,25	15	1/2	0.25	0.25	3.5		
VYG 615 - 0,25 - 0,4				0.4			
VYG 615 - 0,25 - 0,63				0.63			
VYG 615 - 0,25 - 1				1			
VYG 615 - 0,25 - 1,3				1.3			
VYG 615 - 0,25 - 1,8				1.8			
VYG 615 - 0,4 - 0,25			0.4			0.25	
VYG 615 - 0,4 - 0,4						0.4	
VYG 615 - 0,4 - 0,63						0.63	
VYG 615 - 0,4 - 1						1	
VYG 615 - 0,4 - 1,3						1.3	
VYG 615 - 0,4 - 1,8						1.8	
VYG 615 - 0,63 - 0,25			0.63			0.25	
VYG 615 - 0,63 - 0,4						0.4	
VYG 615 - 0,63 - 0,63						0.63	
VYG 615 - 0,63 - 1						1	
VYG 615 - 0,63 - 1,3						1.3	
VYG 615 - 0,63 - 1,8						1.8	
VYG 615 - 1 - 0,25			1			0.25	
VYG 615 - 1 - 0,4						0.4	
VYG 615 - 1 - 0,63						0.63	
VYG 615 - 1 - 1						1	
VYG 615 - 1 - 1,3						1.3	
VYG 615 - 1 - 1,8						1.8	
VYG 615 - 1,3 - 0,25			1.3			0.25	
VYG 615 - 1,3 - 0,4						0.4	
VYG 615 - 1,3 - 0,63						0.63	
VYG 615 - 1,3 - 1						1	
VYG 615 - 1,3 - 1,3						1,3	
VYG 615 - 1,3 - 1,8						1,8	
VYG 615 - 1,8 - 0,25	1.8		0.25				
VYG 615 - 1,8 - 0,4			0,4				
VYG 615 - 1,8 - 0,63			0,63				
VYG 615 - 1,8 - 1			1				
VYG 615 - 1,8 - 1,3			1,3				
VYG 615 - 1,8 - 1,8			1,8				

ZR 2315	Connectors DN 15
ZR 2320	Connectors DN 20



VYG 620

6-WAY CONTROL VALVES
INNER THREADING / PN 16 / DN 20

Fluid temperature: 6...80 °C

- (1) Kvs : flow coefficient: flow rate in m³/h with open valve and 100 kPa pressure drop.
100 kPa = 10 mWG = 1 bar
- (2) bar: maximum differential pressure Δp max. permitted by the actuator
- (3) Rotor type: for 3-way valves: sector = left or right side way always open; butterfly = central way always open

	DN		Kvs (Sequence I) m ³ /h	Kvs (Sequence II) m ³ /h	Suitable actuator CVLR ... 90 sec ⁽³⁾ bar ⁽²⁾					
	mm	inches								
VYG 620 - 0,63 - 1,6	20	3/4	0.63	1.6	3.5					
VYG 620 - 0,63 - 2,5				2.5						
VYG 620 - 0,63 - 4				4						
VYG 620 - 1 - 1,6				1			1.6			
VYG 620 - 1 - 2,5							2.5			
VYG 620 - 1 - 4							4			
VYG 620 - 1,6 - 0,63			1.6						0.63	
VYG 620 - 1,6 - 1									1	
VYG 620 - 1,6 - 1,6									1.6	
VYG 620 - 1,6 - 2,5				2.5						
VYG 620 - 1,6 - 4				4						
VYG 620 - 2,5 - 0,63				2.5				0.63		
VYG 620 - 2,5 - 1			1							
VYG 620 - 2,5 - 1,6			1.6							
VYG 620 - 2,5 - 2,5			2.5							
VYG 620 - 2,5 - 4			4							
VYG 620 - 4 - 0,63			4					0.63		
VYG 620 - 4 - 1				1						
VYG 620 - 4 - 1,6				1.6						
VYG 620 - 4 - 2,5				2.5						
VYG 620 - 4 - 4				4						

RELATED PRODUCTS

ZR 2315	Connectors
ZR 2320	Connectors DN 20



CVLR..

ROTARY ACTUATOR
WITH MANUAL OVERRIDE
5 NM TORQUE
For VYG ... valves

PROTOCOLS
FOR COMMUNICATION



	Power supply V (VA)	Control	Run time sec.	Torque (Nm)	Limit switch (accessory)	Valves connections	Valves DN VYG 2.. VYG 3.. VYG 6..
CVLR 095	24 V AC/DC (2)	3 points	90	5	1 or 2	F04	1/2"÷1"
CVLR 095-0		0...10 V					
CVLR 095-MOD		Modbus					
CVLR 097	100÷240 V AC (4)	3 points					

RELATED PRODUCTS

FCS 123	Auxiliary limit switch with one 3 (0.5) A changeover contact, 250 VAC adjustable 0÷100 %
FCS 223	Auxiliary limit switch with two 3 (0.5) A changeover contact, 250 VAC independently adjustable 0÷100 %



VOBG 3..

SHUTTER VALVES
3-WAY MALE THREADED
PN 16 (-10 ... 120 °C)
BRONZE BODY
DN 1/2"...2", convertible from 3 to 2 ways.

	DN body	DN valve connection male	DN pipe connections female ⁽⁵⁾	Kvs ⁽¹⁾ m ³ /h	run mm	Suitable actuators			
						CLNV ... 7,5 s/mm		CLNF U ⁽⁴⁾ 1,75/7,5 s/mm	
						bar ⁽²⁾	s. ⁽³⁾	bar ⁽²⁾	s. ⁽³⁾
VOBG 311	15	1"1/8	1/2"	0.63	4	56/112	4	112	
VOBG 312				1.0					
VOBG 313				1.6					
VOBG 314				2,5					
VOBG 315				4.0					
VOBG 320	20	1"1/4	3/4"	6.3	15	56/112	4	112	
VOBG 325	25	1"1/2	1"	10					
VOBG 332	32	2"	1"1/4	16					
VOBG 340	40	2"1/4	1"1/2	25					
VOBG 350	50	2"3/4	2"	40					3.5

RELATED PRODUCTS

	Description	Features
TVG G16	1"1/8 female cap complete with gasket	311 ... 315 (15)
TVG G20	1"1/4 female cap complete with gasket	320 (20)
TVG G25	1"1/2 female cap complete with gasket	325 (25)
TVG G32	2" female cap complete with gasket	332 (32)
TVG G40	2"1/4 female cap complete with gasket	340 (40)
TVG G50	2"3/4 female cap complete with gasket	350 (50)

(1) Kvs: flow coefficient: flow rate in m³/h with open valve and 100 kPa pressure drop. .
100 kPa = 10 mWG = 1 bar

(2) bar: maximum differential pressure Δp max. permitted by the actuator

(3) sec: time required for the actuator to make the valve perform its full stroke

(4) Actuator with emergency closure

(5) Female couplings with fittings



VONF 3..

3 WAY FLANGED SHUTTER VALVES
PN 16 (-10 ... 120°C) CAST IRON BODY

Suitable actuators

	DN body mm	Kvs ⁽¹⁾ m ³ /h	Run mm	CLNV ... 7,5 s/mm		CLNF U ⁽⁴⁾ 1,75/7,5 s/mm		CLAV 3,75 s/mm	
				bar ⁽²⁾	s. ⁽³⁾	bar ⁽²⁾	s. ⁽³⁾	bar ⁽²⁾	s. ⁽³⁾
VONF 315	15	4.0	15	4	56 / 112	4	112	-	-
VONF 320	20	6.3							
VONF 325	25	10							
VONF 332	32	16							
VONF 340	40	25							
VONF 350	50	40	3.5		2.8				
VONF 364	65	58	18	2.0	67 / 135	1.6	135		
VONF 365	65	63	30	-	-	-	-	4.0	112/225
VONF 379	80	90	18	1.35	67 / 135	1.0	135	No	No
VONF 380	80	100	30					2.7	112/225
VONF 3100	100	145						1.6	
VONF 3125	125	220	40					0.9	150/30
VONF 3150	150	320						0.6	

RELATED PRODUCTS

ARS 604B Stem heaters for fluid temperatures down to -10°C. 24 V VAC power supply (60W) for valves DN 65:...250

WARNING:

VONF364 and VONF379 models must be coupled with CLNV 318, CLNV 314 and CLNV 354-0 actuators.



VORF 3..

3 WAY FLANGED SHUTTER VALVES
PN 6 (-10 ... 120 °C) CAST IRON BODY

Suitable actuators

	DN body	Kvs ⁽¹⁾ m ³ /h	Run mm	CLNV... 7,5 s/mm		CLNF U... ⁽⁴⁾ 1,75/7,5 s/mm		CLAV... 3,75 s/mm	
				bar ⁽²⁾	s. ⁽³⁾	bar ⁽²⁾	s. ⁽³⁾	bar ⁽²⁾	s. ⁽³⁾
VORF 315	15	4.0	15	4	56/112	4	112	-	-
VORF 320	20	6.3							
VORF 325	25	10							
VORF 332	32	16							
VORF 340	40	25							
VORF 350	50	40	3.5		2.8				
VORF 364	65	58	18	2.0	67/135	1.6	135		
VORF 379	80	90	18	1.35	67/135	1.0	135		
VORF 3100	100	145	30	-	-	-	-	1.6	112/225

WARNING:

VORF364 and VORF379 models must be coupled with CLNV 318 or CLNV 314 and CLNV 354-0 actuators.



CLAV ...

LINEAR AXCTUATORS FOR
VORF .., VONF .. VALVES

	Power supply V (VA)	Control	Position signal	Auxiliary microswitch (accessory) ^(*)	Maximum run mm	Force N	Speed sec./mm
CLAV 214	24 V AC (4.5)	3 points	No	Yes	40	2.500	150 - 40
CLAV 218	230 V AC (9.5)						
CLAV 254-0	24 V AC (6)	0 ÷ 10 V	0 ÷ 10 V				

ACCESSORY FOR AUXILIARY CONTACTS

FCS 2A Auxiliary contacts for globe valve actuators

(*) using FCS2A accessory



CLNV ...

LINEAR ACTUATORS
FOR VOBG .., VORF .., VONF .. VALVES

	Power supply V (VA)	Control	Position signal	Auxiliary microswitch (accessory) ^(*)	Maximum run mm	Force N	Speed sec./mm
CLNV 214	24 V AC (1)	3 points	No	Yes	15	500	150 - 15
CLNV 218	230 V AC (4)						
CLNV 254-0	24 V AC (2)	0÷10 V	0÷10 V		20	1,000	150 - 20
CLNV 318	230 V AC (4,5)	3 points	No				
CLNV 318-R	230 V AC (4,5)						
CLNV 314	24 V AC (3)						
CLNV 314-R	24 V AC (3)	0 ÷ 10 V	0 ÷ 10 V				
CLNV 354-0	24 V AC (3)						
CLNV 354R-0	24 V AC (4,5)						

ACCESSORY FOR AUXILIARY CONTACTS

FCS 2A Auxiliary contacts for globe valve actuators

^(*) using FCS2A accessory



CLNF ...

LINEAR ACTUATORS
FOR VOBG .., VORF .., VONF .. VALVES
WITH EMERGENCY CLOSUREC

	Power supply V (VA)	Control	Position signal	Auxiliary microswitch (accessory) ^(*)	Maximum run mm	Force N	Speed sec./mm	Emergency speed sec./mm
CLNF U254	24 V AC (6)	3 points	No	Yes	20	1000	150-20	35-20
CLNF U254-0		0÷10 V	0÷10 V					
CLNF U254R-0								
CLNF U258-R	230 V AC (4,5)	3 points	No					

ACCESSORY FOR AUXILIARY CONTACTS

FCS 2A Auxiliary contacts for globe valve actuators

^(*) using FCS2A accessory

ACTUATOR	Valves (brand and type)	DN	
upon request	Coster VL - VF (2000÷2010)	65 ÷ 100	
CLNV..R ÷ CLNF U..R	Coster VRG - VRB - VL - VF - VE - VS (2000÷2009)	15 ÷ 50	
	Coster VRGN - VRBN - VLN - VFN (2010)	15 ÷ 50	
	Coster VLN - VFN (2010)	65 ÷ 80	
CLNV...R-0 ÷ CLNF U...R-0	Controlli VSB - VMB - VSB..F - VMB..F	15 ÷ 50	
	Controlli 2FAA, 2FAA...P, 2FAA...T	15 ÷ 80	
	Controlli 2FGA	15 ÷ 100	
	Controlli 2FGB	25 ÷ 150	
	Controlli 3FAA Controlli 3FGB	15 ÷ 80 25 ÷ 150	
CLNV...R-0 ÷ CLNF U...R-0	Honeywell V5011R - V5013R	15 ÷ 50	
	Honeywell V5015	25 ÷ 80	
	Honeywell V5049A - V5050A	15 ÷ 65	
	Honeywell V5095A	20 ÷ 80	
	Honeywell V5328A - V5329A - V5329C	15 ÷ 80	
	Honeywell V5011A - H, J	15 ÷ 100	
	Honeywell V5011N	15 ÷ 50	
	Honeywell V5011S	15 ÷ 50	
	Honeywell V5013A-F	15 ÷ 100	
	upon request	Honeywell V5015A	100 ÷ 150
		Honeywell V5049A - V5050A	80 ÷ 150
CLNV...R-0 ÷ CLNF U...R-0	Siemens VVF61 - VXF61	15 ÷ 25	
	Siemens VPF52E/F - VVF52 - VXF41	15 ÷ 40	
	Siemens VVG41 - VXG41	15 ÷ 50	
	Siemens VVF21 - VVF40	15 ÷ 80	
	Siemens VXF21 - VVF31 - VXF31	25 ÷ 80	
	upon request	Siemens VVF21 - VXF21	100
	Siemens VVF31 - VXF31 - VVF40 - VXF40	100 ÷ 150	
	Siemens VVF41 - VVF45	50 ÷ 150	
	Siemens VVF61	40 ÷ 150	
	Siemens VXF41	65 ÷ 150	
	Siemens VXF61	32 ÷ 150	
	Siemens VMP45	10 ÷ 20	
	Siemens VXP45	10 ÷ 20	

Adapter Kits are available for coupling
Valves / Actuators

ACTUATOR	Valves (brand and type)	DN	
CLNV...R-0 ÷ CLNF U...R-0	Johnson BM-2xx 2 - BM-2xx 8	15 ÷ 50	
	Johnson VB7216	15 ÷ 50	
	Johnson VG7201 - VG7401 - VG7804	15 ÷ 50	
	Johnson VG7203 - VG7403 - VG7802	15 ÷ 50	
	Johnson VB7816	15 ÷ 50	
	Johnson VBD-4xx 4 - VBD-4xx 8 - VG82/84/88/89	15 ÷ 40	
	Johnson VBF-0xx 4 - VBF-0xx 8 - VBF-2xx 4 - VBF-2xx 8	15 ÷ 50	
upon request	Johnson VBD-4xx 8 - VBD-4xx 8 - VG82/84/88/89	50 ÷ 150	
	Johnson VBF-0xx 4 - VBF-0xx 8 - VBF-2xx 4 - VBF-2xx 8	65 ÷ 100	
CLNV...R-0 ÷ CLNF U...R-0	Sauter B6F..F - B6G..F - B6R..F - B6S..F - BXD..F - BXE..F	15 ÷ 50	
	Sauter V6F..F - V6G..F - V6R..F - V6S..F - VXD..F - VXE..F	15 ÷ 50	
	Sauter VXN.. - BXN	15 ÷ 50	
	Sauter B4F..F	20 ÷ 32	
	Sauter BT43B	15 ÷ 40	
	Sauter V1T	15	
	Sauter V4F	15 ÷ 32	
	Sauter BUE.. - BUG.. - VUE.. - VUG	15 ÷ 50	
	upon request	Sauter B6F..F - B6S..F - BXD..F - BXE..F	65 ÷ 150
		Sauter V6F..F - V6S..F - VXD..F - VXE..F	65 ÷ 150
Sauter BUE.. - BUG.. - VUE.. - VUG		65 ÷ 150	
Sauter V4F		40 ÷ 100	
CLNV...R-0 ÷ CLNF U...R-0	Satchwell MJF - VSF	15 ÷ 25	
	Satchwell VZ - MZ	15 ÷ 50	
	upon request		
upon request	Satchwell VSF	32 ÷ 50	
	Satchwell MZF - VZF (pin thread 3/8")	65 ÷ 150	
	Satchwell MZF - VZF (pin thread 1/4")	65 ÷ 150	
	Satchwell MJF (pin thread 1/4")	50	
CLNV...R-0 ÷ CLNF U...R-0	Schneider electric V221	65 ÷ 150	
	Schneider electric V241	15 ÷ 50	
	Schneider electric V265	40 ÷ 65	
	Schneider electric V294	15 ÷ 32	
	Schneider electric V295	40 ÷ 65	
	Schneider electric V211, V211T	15 ÷ 50	
	Schneider electric V341	15 ÷ 50	
	Schneider electric V395-1	40 ÷ 100	

Adapter Kits are available for coupling Valves / Actuators



(1) Kvs: low coefficient: flow rate in m³/h with open valve and 100 kPa pressure drop.
100 kPa = 10 mWG = 1 bar
Vmax low-n: Vmax for low-noise operation



VYQ 2 ...

2 WAY BALL ZONE VALVES (QCV) / INNER THREADING / PN 16

Cold and hot water with max. 50% volume of glycol. Fluid temperature 2...90°C. Brass body. Suitable actuators CVQ 095 - 097. Versions with change over available

	DN body	Rp connection	Kvs ⁽¹⁾ m³/h	PN
VYQ 215 - 1,2	15	1/2	1,2	25
VYQ 215 - 4,8			4,8	
VYQ 220 - 8	20	3/4	8	

VZC 2 ...

PRESSURE INDEPENDENT CONTROL VALVES (PIQCV) / INNER THREADING / DN 15 - 25

Cold and hot water. Brass body. Suitable actuators CVQ 095 - 097

	DN body	Rp connection	Vnom l/h	PN	Sv min.
VZC 215-P-B	15	1/2	210	25	100
VZC 215-P-D			420		
VZC 215-PT-B			210		
VZC 215-PT-D	420				
VZC 220-P-F	20	3/4	980		
VZC 220-PT-F			980		
VZC 225-PT-G	25	1	2100		

RELATED PRODUCTS

ZR 2315	Connections DN 15
ZR 2320	Connections DN 20
ZR 2325	Connections DN 25

CVQ 0...

ROTARY ACTUATOR FOR ZONE VALVES AND PIQCV

Quick-mounting actuator For VZC 2 .. valves

	Power supply V (VA)	Control	Run time sec.	Torque (Nm)	Limit switch (accessory)
CVQ 095	24 VAC/DC (0.6)	3 points	75	1	No
CVQ 095-0	24 VAC/DC (0.6)	0..10V			
CVQ 097	230 VAC (2)	3 points			



CSL ..., CSN ..., CSS ..., CSG ...

DAMPER ACTUATORS

Actuators suitable for operating dampers in air handling units.

	Power supply V (VA)	Control	Auxiliary contact	Dampers m ²	Torque N/m	Run sec.
CSL 138	230V AC (4)	2 or 3 points	-	1	5	150
CSL 138/C			1			
CSL 134	24V AC/DC (2)	2...10V-	-	1	5	
CSL 134/C			1			
CSL 104			-			
CSN 238	230V AC (6)	2 or 3 points	-	2	10	
CSN 238/C			1			
CSN 234	24V AC/DC (4)	2...10V-	-	2	10	
CSN 234/C			1			
CSN 204			-			
CSS 438	230V AC (6)	2 or 3 points	-	4	20	
CSS 438/C			1			
CSS 434	24V AC/DC (4)	2...10V-	-	4	20	
CSS 434/C			1			
CSS 404			-			
CSG 838	230V AC (8)	2 or 3 points	-	8	40	
CSG 838/C			1			
CSG 834	24V AC/DC (7)	2...10V-	-	8	40	
CSG 834/C			1			
CSG 804			-			



FCS ... - FCF 223 - PCS 104

LIMIT SWITCH CONTACT FOR DAMPER ACTUATORS

FCF 223	Auxiliary limit switch contact with 2 changeover contacts 3 (0,5)A, 250V AC for CFS... actuators
FCS 123	Auxiliary limit switch contact with 1 changeover contact 3 (0,5)A, 250V AC for CS... actuators
FCS 223	Auxiliary limit switch contact with 2 changeover contacts 3 (0,5)A, 250V AC for CS... actuators
PCS 104	Positioner 0...100% actuator dampers 0 - 10V DC (max 10 actuators)

KH ..., AH..., KG ..., ZG ...

ACCESSORIES REQUIRED TO COUPLE ACTUATORS TO THE DAMPERS

AH-20	Lever for CSS... actuators
AH-25	Lever for CSN... actuators
AH-TF	Lever for CFT... actuators
AH-GMA	Lever for CSG... actuators
KH 8	Universal lever for damper pins (Ø10 ... 18 mm.; ⌀ 10 ... 14 mm.)
KG 10	Ball joint connection (use rods with Ø max. 10 mm.)
KH-AFB	Lever for CFS.. actuators
KH-LF	Lever for CFL... actuators
ZG-GMA	Kit for mounting actuator on the flat for CSG... actuators
ZG-NMA	Kit for mounting actuator on the flat for CSN... actuators
ZG-SMA	Kit for mounting actuator on the flat for CSS... actuators
ZG-AFB	Kit for mounting actuator on the flat for CFS... actuators
ZG-LF1	Kit for mounting actuator on the flat for CFL... actuators
ZG-TF1	Kit for mounting actuator on the flat for CFT... actuators

ACCESSORIES REQUIRED TO COUPLE ACTUATORS TO THE DAMPERS

- 1 actuator for 1 damper:
 - direct mounting on the damper pin, no accessory is required;
 - remote mounting No. 1 AH..., No. 1 KH8, No. 2 KG 10 and No. 1 rod⁽¹⁾.
- 1 actuator for 2 dampers:
 - direct mounting on pin of damper No. 1 AH..., No. 1 KH8, No. 2 KG 10 and No. 1 rod⁽¹⁾;
 - remote mounting No. 1 AH..., No. 2 KH8, No. 3 KG 10 and No. 2 rods⁽¹⁾.
- 1 actuators for 3 dampers:
 - direct mounting on pin of damper No. 1 AH..., No. 2 KH8, No. 3 KG 10 and No. 2 rods⁽¹⁾;
 - remote mounting No. 1 AH..., No. 3 KH8, No. 4 KG 10 and No. 3 rods⁽¹⁾.



⁽¹⁾ Universal joint connecting rods: 8/10 mm round rod (available from any hardware store)



CFT ..., CFL ..., CFS ...

DAMPER ACTUATORS WITH EMERGENCY CLOSURE

Actuators suitable for operating dampers in air handling units. Automatic closure of the damper in the event of power failure.

	Power supply V (VA)	Control	Auxiliary contracts	Dampers m ²	Torque N/m	Run sec.	Emergency sec.
CFT 028	230V~ (5)	2 points	-	0.4	2	75	25
CFT 028/C			1				
CFT 024	24V~/-(5)	2...10V-	-	0.8	4	150	20
CFT 024/C			1				
CFT 004							
CFL 128	230V~ (7)	2 points	-	0.8	4	75	20
CFL 128/C			1				
CFL 124	24V~/-(7)	3 points	-	4	20	150	20
CFL 124/C			1				
CFL 134	24V~/-(5)	2...10V-	-	4	20	75	20
CFL 104							
CFS 428	230V~ (18)	2 points	-	4	20	75	20
CFS 428/C			2				
CFS 424	24V~/-(7.5)	2...10V-	-	4	20	150	20
CFS 424/C			2				
CFS 404	24V~/-(7)	2...10V-	-	4	20	150	20
CFS 404/C			2				

A wireframe architectural rendering of a modern building, composed of a complex grid of white lines. The building is set against a dark blue background. A prominent horizontal band of bright green color runs across the middle of the image, containing the text "PROBES AND SENSORS" in white, bold, uppercase letters. The building's structure is intricate, with many lines overlapping and creating a sense of depth and complexity. The base of the building is reflected on a dark surface, and there are some faint lines on the ground suggesting a street or parking area.

PROBES AND SENSORS



THP 868

WIRELESS TEMPERATURE/HUMIDITY
FOR CIVIL INSTALLATION

Temperature and relative humidity sensors in 80 x 80 x 25 mm container. Can be combined with CSW 868 concentrator.
Battery power supply



COP 868

WIRELESS TEMPERATURE/HUMIDITY/CO₂
FOR CIVIL INSTALLATION

Combined sensor in 80 x 120 x 25 mm container. It can be combined with CSW 868 wireless concentrator.
Battery power supply



STT-STU.H

WIRELESS SENSORS
FOR INDUSTRIAL INSTALLATION

Watertight temperature sensors in 105 x 105 x 55 mm container. They can be combined with CSW 868 concentrator.
Battery power supply

STT 868H	Wireless watertight temperature sensor
STU 868H	Wireless watertight temperature-humidity sensor



PROTOCOL
FOR COMMUNICATION



CSW 868

WIRELESS SENSORS CONCENTRATOR

System module enabling a wireless connection (LoRa 868MHz) with one or more wireless devices (up to 40), such as sensors, actuators and pulse meters:

- THP 868,
- PCP 868
- COP 868
- STT 868H
- STU 868H
- ATR 868

Compatible with Y/Z series controllers and gateways EHC 602 / YHC 700. 12V DC power supply.
1 module DIN enclosure.
ANTENNA INCLUDED.

RELATED PRODUCTS

APA 500	SMA antenna extension, length 5 meters
ANT 868	Upgraded antenna for 868 concentrators
USB 485	Required for direct connection with YLC 880, CSW 868 controllers



SWB 912

T/H WIRELESS SENSOR READING KIT

The SWB 912 KIT enables the acquisition of THP 868 radio sensors via the X-series equipment... without changing the hardware in the field.
The acquired variables are temperature.
It consists of CPX 912, CSW 868 S1, ALM 1210 power supply and ANT 250 antenna.



PROTOCOL
FOR COMMUNICATION



SAC 002

ROOM TEMPERATURE CO₂ AND RELATIVE
HUMIDITY SENSOR

Room sensor for wall installation for CO₂ temperature and humidity detection in MODBUS and M-bus protocol.
Temperature detection and transmission on NTC resistive output 10kΩ.
Measurement detection on 0-10V outputs.
12...24 VAC/VDC power supply⁽¹⁾

⁽¹⁾ When used in M-Bus takes power from the Bus



STA 0..

AIR DUCT TEMPERATURE SENSORS

The 1W version can acquire and transmit temperature values.

STA 001W	Air duct temperature sensor 1W (-30... 100 °C) Only for YLC controllers
STA 002	PT 1000 air duct temperature sensor . (-20...100 °C)
STA 010	Air duct temperature sensor (0...100 °C), NTC 10 KΩ
STA 001	Sonda di temperatura per canali aria di ripresa (-30...+40 °C) NTC 1 KΩ



SAF 00..

CABLE TYPE TEMPERATURE SENSOR

Installation in watertight pocket

SAF 001	Cable type temperature sensor (-40...+40 °C). NTC 1 KΩ
SAF 001W	Cable type temperature sensor (0...100 °C). Only for YLC controllers.
SAF 002	Cable type temperature sensor PT 1000 (0...100 °C).
SAF 010	Cable type temperature sensor (0...100 °C). NTC 10 KΩ.
SAF 110	Cable type temperature sensor with 2 sensors and 4 wires (0...100 °C). NTC 10 KΩ.

RELATED PRODUCTS

GIS 090	Brass seal 1/2" x 90 mm complete with grommet; PN10
GIS 090/Inox	Stainless steel seal 1/2" x 90 mm complete with grommet; PN16
GIS 160	Brass seal 1/2" x 160 mm complete with grommet;; PN10
GIS 160/Inox	Stainless steel seal 1/2" x 160 mm complete with grommet; PN16
GIS 500	Brass seal 1/2" x 500 mm complete with grommet; PN10
GIS 500/Inox	Stainless steel seal 1/2" x 500 mm complete with grommet; PN16
ACM 103	Connection box with terminal block and adapter for old COSTER seals



SAB 002

PT 1000 ROOM SENSOR



SAE 00.

OUTSIDE TEMPERATURE SENSOR

Measures outside temperature

SAE 001	Outside temperature sensor (-40 ... +40 °C), NTC 1 KΩ
SAE 002	Outside temperature sensor PT 1000 only for YLC controllers



SAE 420

DIGITAL OUTDOOR SENSOR CURRENT MODULATION

Only for YLC and ZBC controllers (can be connected to YLC and ZBC analogue input)



SIH 00..

IMMERSION SENSOR

Contact fluid carrier installation.

SIH 001W	Immersion sensor 1W (0...100 °C). Only for YLC controllers.
SIH 002	Immersion sensor PT 1000 (0...100 °C).
SIH 010	Immersion sensor with brass pocket (0...100 °C)NTC 10 KΩ.
SIH 010/Inox	Immersion sensor with stainless steel pocket (0...100 °C) NTC 10 KΩ.

RELATED PRODUCT TO SIH 010

APV 100	Accessory for adapting to old COSTER seals
----------------	--



SCH 00..

CONTACT TEMPERATURE SENSOR

For installation in contact with pipework

SCH 001W	Surface temperature sensor 1W (0...100 °C).
SCH 002	Surface temperature sensor PT 1000 (0...100 °C).
SCH 010	Surface temperature sensor (0...100 °C). NTC 10KΩ



SAB 0../SF - SAI 0../SF

ROOM TEMPERATURE SENSORS WITH
OR WITHOUT SETPOINT ADJUSTER

Sensors for measuring room temperature (measuring range 0...40 °C).

SAB 002/SF	Flush-mounted room sensor without specific plug	PT 1000
SAB 010	In wall container 80 x 80 x 32	NTC 10 kΩ
SAB 010/SF	Flush-mounted room sensor without specific plug	NTC 10 kΩ
SAB 020	Double sensor in wall container 80 x 80 x 32	NTC 20 kΩ
SAI 010	Radiation sensor, in wall container 80 x 80 x 26	NTC 10 kΩ



SGG - SGE ...

OUTSIDE TEMPERATURE SENSOR
FOR "DAY DEGREES" MEASUREMENT

Specific outside temperature sensors for day degrees measurement. The sensor is provided with mechanics unaffected by radiated heat, as established by the standards of the day degrees measurement.

SGG 001	High-precision outside temperature sensor specifically for the XGG 618 standardised degree-day meter
SGE 001	Outside temperature sensor compatible with all climate controllers, for measuring day degrees included in these controllers

The exact compatibility of the sensors with the devices is indicated in the device manuals, which can be found at www.costergroup.eu



SAA ...

WATERTIGHT ROOM TEMPERATURE SENSOR

Measurement of room temperature in very humid rooms (e.g. greenhouses). Measurement of very high and humid room temperatures (80...90 °C).

SAA 001	Watertight room sensor (- 30...+40 °C), NTC 1 KΩ
SAA 010	Watertight room sensor (0...+100 °C), NTC 10 KΩ



STH 001

IMMERSION TEMPERATURE SENSOR (0...300 °C)

Type PT 1000



SIR 010

DIRECT IMMERSION TEMPERATURE SENSOR (0...100 °C)

The sensor is in direct contact with water to increase the response speed. Indispensable, for example, for controlling instantaneous domestic hot water mixing.
Type NTC 10 KΩ



STT 010

TEMPERATURE SENSOR
FOR TERMINAL UNITS (0...40 °C)

Type NTC 10 KΩ



STF 001

FLUE GAS TEMPERATURE SENSOR (0...500 °C)
Type PT 1000



SHF 001

CABLE TYPE TEMPERATURE SENSORS (0...180 °C)
POCKETS AND ACCESSORIES FOR CABLE TYPE
TEMPERATURE SENSORS

SHF 001	Cable type temperature sensors 0...180 °C (0...180 °C), Pt 1000
----------------	---

RELATED PRODUCTS

GIS 090	Brass pocket 1/2" x 90 mm complete with grommet PN10
GIS 090/Inox	Stainless steel pocket 1/2" x 90 mm complete with grommet PN16
GIS 160	Brass pocket 1/2" x 160 mm complete with grommet PN10
GIS 160/Inox	Stainless steel pocket 1/2" x 160 mm complete with grommet PN16
GIS 500	Brass pocket 1/2" x 500 mm complete with grommet; PN10
GIS 500/Inox	Stainless steel pocket 1/2" x 500 mm complete with grommet PN16
ACM 103	Connection box with terminal block and adapter for old COSTER seals



SAU 914

ROOM RELATIVE HUMIDITY AND
TEMPERATURE SENSOR (0...50 °c)

24 Volt AC power supply, or 12 V - from COSTER devices, if equipped with 12 Volt auxiliary power supply.
Humidity output signal: active 0...5 V- or 0...10 V-.



SPW 2..

ABSOLUTE PRESSURE SENSORS
FOR LIQUIDS

24 Volt AC/DC power supply.
Output signal: 0 - 10 V-

SPW 204	Absolute pressure sensor for liquids (0...4 bar)
SPW 210	Absolute pressure sensor for liquids (0...10 bar)
SPW 216	Absolute pressure sensor for liquids (0...16 bar)



SUR 704

RELATIVE HUMIDITY SENSOR FOR AIR DUCTS

24 Volt AC power supply, or 12 V - from COSTER devices, if equipped with 12 Volt auxiliary power supply.
Output signal active: 0...5 V- or 0...10 V-



SDW 2..

DIFFERENTIAL PRESSURE SENSORS
FOR LIQUIDS PER LIQUIDS

24 Volt AC/DC power supply.
Output signal: 0 - 10 V-

SDW 201	Differential pressure sensor for liquids (0...1 bar)
SDW 202	Differential pressure sensor for liquids (0...2,5 bar)
SDW 206	Differential pressure sensor for liquids (0...6 bar)



SUT 734

HUMIDITY AND TEMPERATURE SENSOR
FOR DUCTS

Power supply: 15...24 V = (±10%) or 24 V ~ (±10%) SELV.
Output voltage: 2x 0..10 V or 0..5 V, configurable via jumper, min. load 10 kΩ
NTC passive output 10k.



SDA 700

DIFFERENTIAL PRESSURE TRANSDUCER
(- 100...+2500 Pa SETTABLE)

Differential pressure transducer with 8 selectable measuring ranges and adjustable output signal (0...10 V or 4...20mA).
Power supply : 15...35 VDC or 19 ... 29 VAC (± 10%);



SQC 954

ROOM VOC SENSOR



LGP ...

LIQUID LEVEL PRESSURE SENSORS

Water, diesel or other liquids tank level measurement by detecting the hydrostatic pressure of the liquid.

12 Volt -power supply from COSTER devices (UML 318)

- LGP 250 Liquid level pressure sensor (water 0...2.5 m)
- LGP 500 Liquid level pressure sensor (water 0...5 m)

RELATED PRODUCT

- UML 318 Unit of measurement, alarm and storage for various signals



SQS 954

DUCT VOC SENSOR



UPA 798

ELECTROMECHANICAL ROOM HUMIDOSTAT

On-Off control of humidification or dehumidification units.
Wall mounting.



SAL 500

ANTI-FLOODING SENSOR



UAL 358

CONTROL AND ALARM UNIT
FOR UP TO THE THREE
ANTI-FLOODING SENSORS

Alarm system to detect flooding caused by plumbing leaks.

- SAL 500 Anti-flooding sensor
- UAL 358 Control unit for up to 3 anti-flooding sensors



UPC 799

DUCT ELECTROMECHANICAL HUMIDOSTAT

On-Off control of humidification or dehumidification units.
Duct assembly.



TAG 797

ELECTROMECHANICAL FROST PROTECTION
THERMOSTAT

Suitable for frost protection of hot water heating batteries.



PDF 795

DIFFERENTIAL PRESSURE SWITCH

Indication of filter unit cleanliness status or fan functioning.

- Setting range: 50 ... 500 Pa
- Triggering differential: 20 Pa +/- 15% (100 kPa = 1 bar)
- Maximum pressure: 5 kPa



CDB ...

REMOTE CONTROLS FOR VARIOUS CONTROLLERS

They are desired room temperature set point adjusters or other equipment, with or without sensors.

	Description	Compatible controllers
CDB 100	Temperature set point adjuster with room sensor (0...40 °C)	DRU 414/418, DTF/RTF 31, DTT 318; XTU 614/618, XTU 644, XTU 664, XTA 624, XTR 628
CDB 200	Humidity calibration adjuster with room sensor (0...40 °C)	XTU 614, XTU 644, XTU 664
CDB 300	Modifica programmi per regolatori climatici	XTP 600, XTT 608, XTE 611, XTE 600/602, XSE 600/602
CDB 300/S1	Programme change for climate controllers (0...40 °C)	XTP 600, XTT 608, XTE 611, XTE 600/602, XSE 600/602
CDB 301	Programs change for climate controllers on DIN 3 box unit	XTP 600, XTT 608, XTE 611, XTE 600/602, XSE 600/602
CDB 333	Programs change	XCS 633, XSS 633, XTU 618



CONNECTIVITY AND ACCESSORIES



SWC 701

FREE REMOTE CONTROL SOFTWARE DOWNLOADABLE FROM THE INTERNET

Application software for managing communications between central computer and peripheral units (central heating plants, systems). Downloadable from the website www.costergroup.eu after registration. MANUAL AND INFORMATION ON THE WEBSITE: www.costergroup.eu, product menus, remote control documentation.

SWC 701	Device remote control software RS 232 and C-BUS.	free download
----------------	--	---------------



TCH ...

HMI TOUCH FROM 7 OR 10 INCHES

Touch HMI used for local management of Building Automation systems where the WebGarage platform is present. TCH ...acts as a dedicated user interface for browsing web pages generated and displayed by the EHC ...edge device with integrated WebGarage.

TCH 102	10 inch Touch HMI
TCH 072	7 inch Touch HMI

RELATED PRODUCT

EHC ...	Multi-protocol edge device
----------------	----------------------------



CosterTools

Downloadable from the website www.costergroup.eu upon registration CosterTools is the complete software ecosystem designed to support professionals at every stage: from design and programming to commissioning and remote management. A suite of powerful and flexible tools to maximise the efficiency of control systems. CosterCAD - Evolved and Flexible Programming. The heart of system design. CosterCAD allows dynamic programming by adapting to any technical requirement.

CosterCAD – Evolved and Flexible Programming
Il cuore della progettazione degli impianti. CosterCAD permette una programmazione dinamica adattandosi a ogni esigenza tecnica:

- The heart of system design. CosterCAD allows dynamic programming by adapting to any technical requirement;
- Block logics: to simplify and speed up standard controller configuration
- CosterDiagram: for free and customised programming, ideal for handling complex scenarios with maximum precision.

Cadebugger – Commissioning and Parameterisation
The essential tool for commissioning. An extremely user-friendly tool designed to facilitate the technician during the initial setup, allowing quick and intuitive parameterisation of all the system components.

Wireless Device Configurator – Wireless Ecosystem
The dedicated solution for managing wireless environments. Allows complete configuration of the wireless network, guaranteeing stability and precision in both monitoring and temperature and room comfort control activities.

ClimaOffice – Simplified Remote Management for the Y-Series
The ideal platform for remote control. ClimaOffice makes the remote management of Y-Series installations simple and straightforward, allowing you to monitor performance and take timely action wherever you are.

CosterTools	Software suite	free download
--------------------	----------------	---------------



PROTOCOLS FOR COMMUNICATION



RUT 302

ROUTER 4G

4G router with RS 485 and C-BUS serial communication ports and Ethernet port. Configurable via integrated webserver. Power supply 12..24 VDC and VAC. In 3 DIN module housing.

RELATED PRODUCTS

ETH 338	Ethernet cross-over cable for RUT 302 and ARE 338 direct connection
APA 500	SMA antenna extension, length 5 meters
ANT 500D	Directional antenna



PROTOCOLS FOR COMMUNICATION

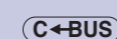

ARE 338

ETHERNET/C-BUS CONVERTER

Connection of devices equipped with C-Bus to the Ethernet. Only for X-series controllers.



RUT 002

ROUTER 4G

With high-speed wireless and Ethernet connections. Power supply unit included.



PROTOCOLS FOR COMMUNICATION



RS 232

MDM 0..

DESKTOP MODEM

Desktop modem for Clima Office and SWC 701.

- MDM 002** Desktop modem with USB port, powered via USB
- MDM 003** Desktop modem with RS232 port with dedicated power supply

RELATED PRODUCT

- APA 500** SMA antenna extension, length 5 meters



SWH 005

5 PORT ETHERNET SWITCH



PROTOCOLS FOR COMMUNICATION

RS 232

MDM 232

GSM MODEM

The MDM 232 modem provides two-way communication between the YLC 880, YHC 700 and the supervisory system via an M2M SIM CARD with 2G connectivity.

Power supply 12 V DC Antenna included
1 module DIN enclosure.



PROTOCOLS FOR COMMUNICATION

C-BUS RS 232

ACB 332

LOW POWER C-BUS AMPLIFIER AND CONVERTER

It amplifies the C-Bus line, with speeds from 1200 to 9600 bps. Converts C-Bus to RS 232 for connection with PC or modem with RS 232, but no C-Bus. Only for X-series controllers.



PROTOCOLS FOR COMMUNICATION

C-BUS

KIT 668

KIT AS ALTERNATIVE TO GSM 668

GSM/GPRS modem complete with 12 V DC power supply unit and C-Bus/RS-232 converter

NB: Replaces GSM 668



PROTOCOLS FOR COMMUNICATION

RS 232

PCB 332

MEDIUM POWER C-BUS AMPLIFIER AND CONVERTER

It amplifies the C-Bus line, with speeds from 1200 to 9600 bps. Converts C-Bus to RS 232 for connection with PC or modem with RS 232, but no C-Bus.

Only for X-series controllers.



PROTOCOLS FOR COMMUNICATION

Modbus RS 232

GTW 232485

RS 232 - RS 485 CONVERTER

Device enabling conversion between RS232 and 485 serial. It ensures bidirectional communication between the units connected to it. It can only be used with YLC 740 and YLC 780 controllers.

12 V DC power supply.
In 1 module DIN enclosure.



PROTOCOLS FOR COMMUNICATION

C←BUS RS 232

PCB 432

HIGH POWER C-BUS AMPLIFIER AND CONVERTER

It amplifies the C-Bus line, with speeds from 1200 to 9600 bps. Converts C-Bus to RS 232 for connection with PC or modem with RS 232, but no C-Bus. Extensive connection possibilities with devices, local or remote PC, and modem. Only for X-series controllers.



PROTOCOLS FOR COMMUNICATION

C←BUS RS 232

GVC 348

C-BUS SPEED CONVERTER FROM 1200...9600 BPS AND VICE VERSA

It amplifies and realigns the C-Bus, with speeds from 1200 to 9600 bps. It allows the connection of devices with different C-Bus speeds to the same line. Only for X-series controllers.



PROTOCOLS FOR COMMUNICATION

C←BUS

UCO 318

ON-OFF TIME PROGRAMMER WITH CHANNEL

It allows an On-Off control with timed programming of any type: Only for X-series controllers.



PROTOCOLS FOR COMMUNICATION

C←BUS

UCO 638

ON-OFF TIME PROGRAMMER WITH 3 CHANNELS

It allows 3 On-Off controls of three electrical devices with timed programming. Only for X.. series control units.



PROTOCOLS FOR COMMUNICATION

C←BUS

UAC 32.

UNIT FOR ACQUISITION AND LOGGIN ALARM, STATUS AND COUNTS, WITH 8 ON-OFF INPUTS

It can collect 8 On-Off signals of alarm, status, time counts and number of pulses.

Only for X-series controllers

UAC 328	Unit for acquisition and login alarm, status and counts	230 V AC
UAC 324	Unit for acquisition and login alarm, status and counts	24 V AC



PROTOCOLS FOR COMMUNICATION

C←BUS

UML 318

MEASUREMENT, RECORDING AND ALARM UNIT FOR ANY ACTIVE SIGNAL

Transforms an analogue 0...5 Volt, or 0...10 Volt, or 4...20 mA signal into the measurement of a physical quantity.

It includes: measurement, alarms and recording the value of the physical quantity.

Suitable for processing the signal of the:

- LGP pressure level sensor
- SDA differential pressure sensor for air
- other sensors with analogue output of any kind.

RELATED PRODUCTS

LGP 250	Pressure level sensor (0...0,25 bar)
LGP 500	Pressure level sensor (0...0,50 bar)
SDA 700	Sonda di pressione differenziale per aria
.....	Any sensor with 0...5 Volt DC, 0...10 Volt DC, 4...20 mA output



PROTOCOLS FOR COMMUNICATION

C←BUS

ULT 3..

TEMPERATURE RECORDING UNIT

It allows 4 temperature measurements/alerts to be acquired and the trend to be stored and recorded.

Programmable minimum and maximum alarms.

Sensor that can be connected

		NTC 10 kΩ 0...99 °C	NTC 10 kΩ 0...40 °C	NTC 1 kΩ -40...40 °C
ULT 328	Temperate recording unit.	2	1	1
ULT 348	Temperate recording unit.	4	-	-
ULT 348/S1	Temperature recording unit for 4 room sensors used for air handling units	-	4	-



PROTOCOLS FOR COMMUNICATION

C←BUS RS 232

ACX 232

PLUG IN TEST FOR DIN DEVICES TYPE X..

Allows a local PC to be connected to a COSTER device equipped with a "SLOT".
Allows, where applicable, update of the device software with the software tool.



PROTOCOLS FOR COMMUNICATION

C←BUS

ACB 4..

PLUG IN FOR COMMUNICATION VIA C-BUS FOR X SERIES CONTROLLER

Allow remote management via C-Bus of "C-Bus preconfigured" devices. The documentation and front panel of each device indicate the required model of ACB 4... plug-in.

ACB 400	Plug-in for communication via C-Bus
ACB 460	Plug-in for communication via C-Bus
ACB 468	Plug-in for communication via C-Bus



PROTOCOLS FOR COMMUNICATION

RS 232

ACS 232

RS 232 CABLES WITH DB 9 MALE (FOR MODEM OR SIMILAR)

It is a 0.5 metre cable for connecting 3 RS 232 output terminals, to a PC or modem.



PROTOCOLS FOR COMMUNICATION

C←BUS RS 232

ACB 232

C-BUS TO RS 232 CONVERSION CABLE OF A PC

NO MODEM

It is used to connect up to 5 COSTER devices equipped with C-Bus to the PC.

Not to the modem, since the power supply is missing.



PROTOCOLS FOR COMMUNICATION

C←BUS RS 232

ACB 232/S1

C-BUS TO RS 232 CONVERSION CABLE OF A PC OR MODEM POWERED BY COSTER DEVICES

It is used to connect up to 5 COSTER devices equipped with C-Bus to the PC, or to a modem, as it can be directly powered by a device with a 12 V auxiliary power supply -. (e.g.: UCO 318 and UCO 638)

COSTER

costergroup.eu

PESCHIERA BORROMEO

Via Giuseppe di Vittorio, 24
20068 Peschiera Borromeo (MI)
tel: (+39) 022722121
info@costergroup.eu

EDOLO

Via Gen. Treboldi, 190/192
25048 Edolo (BS)
tel: (+39) 0364773211

